

MICRO™

THE 6502 JOURNAL

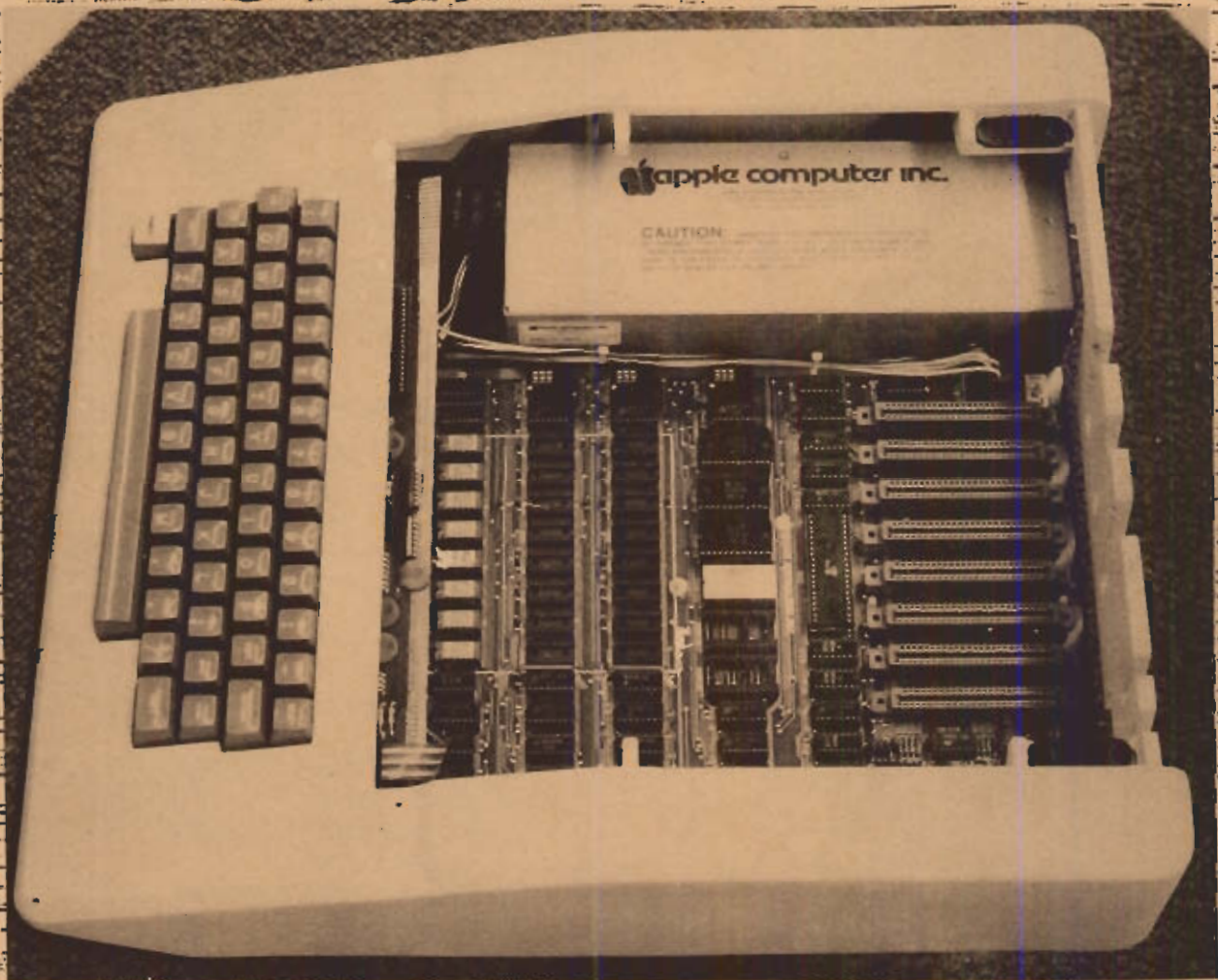

Inside the APPLE II

NO 1

Oct - Nov 1977

\$ 1.50

QUICK CHANGE ARTISTRY

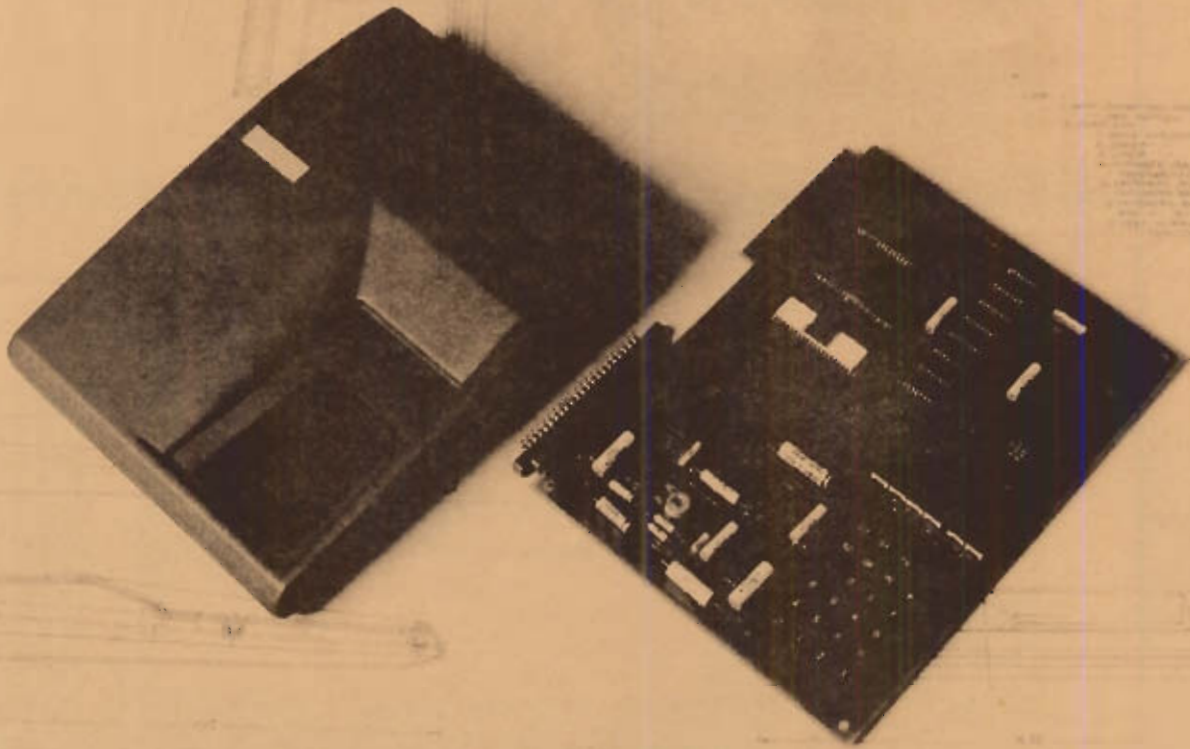

ENGINEERED SPECIFICALLY FOR THE KIM-1 MICRO COMPUTER

- Protection of Chips and Other Components
- Viewing Angle of Readout Enhanced
- Improved Keyboard Position for Easier Operation

EASILY ASSEMBLED

- Absolutely No Alteration of KIM-1 Required
- All Fasteners Provided
- Goes Together in Minutes with a Small Screwdriver

ATTRACTIVE FUNCTIONAL PACKAGE

- Professional Appearance
- Four Color Combinations
- Improves Man/Machine Interface

MADE OF HIGH IMPACT STRENGTH THERMOFORMED PLASTIC

- Kydex 100*
- Durable
- Molded-In Color
- Non-Conductive

AVAILABLE FROM STOCK

- Allow Two to Three Weeks for Processing and Delivery
- No COD's Please
- Dealer Inquiries Invited

TO ORDER: 1. Fill in this Coupon (Print or Type Please)
2. Attach Check or Money Order and Mail to:

NAME _____

STREET _____

CITY _____

STATE _____ ZIP _____

Please Ship Prepaid _____ SKE 1-1(s)
@ \$23.50 Each
California Residents please pay
\$25.03 (Includes Sales Tax)

**the
enclosures
group**

55 stevenson, san francisco 94105

Color Desired blue beige
black white

CHEAP MEMORY for the KIM-1 by Byron Salzsieder - has an expanded KIM-1, KIMSI, and is currently waiting for delivery of a Micromind.	3
Terminal Interface Monitor (TIM) for the 6500 Family by Oliver Holt - "The Computer Doctor" for Microcomputers, Inc., microcomputer teacher and consultant, micro-systems designer.	5
We're Number One ! An Editorial	6
INSIDE the APPLE II by Arthur Ferruzzi - a confirmed "computer nut" who owns a number of 6502 microcomputers - assembled, kit and homebrew.	9
Rockwell International and the 6502 by Arthur Ferruzzi - currently designing some special purpose micro-systems, 6502 based, of course.	10
The PET'S IEEE-488 Bus: Blessing or Curse? by Charles Floto - Editor of <u>Buss</u> and <u>Yankee Bits</u> and freelance writer and photographer whose work has appeared in <u>Byte</u> , <u>Personal Computing</u> , and <u>Kilobaud</u> .	11
6502 RELATED COMPANIES by Mike Rowe - prefers hexadecimal notation since he has eight fingers on each hand.	12
HYPERTAPE and ULTRATAPE by Robert M. Tripp - Editor of MICRO, author of PLEASE and other software and hardware for the KIM-1.	13
KIM-Based Degree Day Dispatcher by Mike Rowe - Computer consultant for the Starship Enterprise.	17
COMPUTER CONTROLLED RELAYS by Robert M. Tripp - Microprocessor consultant and lecturer.	19
6502 Bibliography by William Dial - Retired Research Chemist with a KIM-1 and several 6502-based OSI boards.	21
6502 Reference Card	Back Page

Subscription rate: \$6.00 per year (six issues) in U.S.

MICRO is published bimonthly by The COMPUTERIST, 8 Fourth Lane, So. Chelmsford, MA 01824. Robert M. Tripp, Publisher.
Application to mail at controlled circulation rates pending at Chelmsford, MA 01824.

Copyright 1977 by The COMPUTERIST. All Rights Reserved.

THE
COMPUTERIST

KIM-1 Microcomputer: with molded plastic enclosure	\$249.00	
Molded Plastic Enclosure: specifically designed for KIM-1	\$23.50	
PLEASE: A collection of games and demos for the KIM-1. Includes a 24 Hour Clock, Mastermind, Shooting Stars, Drunk Test,	\$15.00	
MICROCHESS: Play a good game of chess on a standard KIM-1.	\$15.00	
HELP Editor: Text and Source Editors and Printers	\$15.00	
HELP Mailing List: Maintain and selectively print mailing lists.	\$15.00	
HELP Information Retrieval: Create and maintain a data base on cassette and selectively retrieve data using multiple tests.	\$15.00	
NOTE: All programs run on standard KIM-1 with no additional memory. All come on cassette and include full instructions and source listings. HELP programs require TTY and two computer controlled cassettes.		
HELP Relay Package: All components for controlling two cassette recorders: reed relays, buffer chip, diodes,... No PC Board.	\$15.00	
POWER SUPPLY: +5V and +12V for a KIM-1 and KIM-2. Completely assembled, enclosed and protected. Run from AC or car battery.	\$40.00	
DIGITAL/ANALOG CONVERTER: Includes hifi section and filters. Play Star Spangled Banner and Exodus in four-part harmony. Assembled and tested. Full documentation, listings, and programs on cassette.	\$35.00	
4K RAM Memory Board: Assembled, socketted, tested. Limited quantity.	\$129.00	

SUB TOTAL

Massachusetts Residents add 5% Sales Tax:

Overseas add 10% surface or 20% air mail for Software or Relays
Overseas must pay actual freight for KIM-1, Power Supply, or DAC
Foreign checks must be drawn on Boston or New York banks.

TOTAL

Name:

Addr:

City: State: Zip:

All orders must be prepaid. Handling and shipping charges within the continental United States are included in prices. Make checks payable to: The COMPUTERIST. Send order to:

The COMPUTERIST, P.O. Box 3, S Chelmsford, MA 01824

CHEAP MEMORY for the KIM-1

Byron Salzsieder
185 Franklin
Cambridge, MA 02139

When it's time to add another 4K of memory to your KIM-1, for less than half the price of a KIM-2 (which is no longer available anyway) you can add a Veras Systems 4K Byte Memory Board. Veras Systems attempted to market an F8 microprocessor based system, unsuccessfully, and are no longer in the business. The 4K RAM memory board they designed is, however, avail-

able in kit form and can be modified to work with the KIM-1 without very much effort.

The Veras bus used the same 44-pin socket as the KIM, but the various lines were connected to different positions. The following table shows the connections required when you make a cable to connect the KIM to the memory.

KIM to VERAS Connections

KIM PIN	FUNCTION	VERAS PIN	KIM PIN	FUNCTION	VERAS PIN
22	VSS GND	12 (See Note)	Z	RAM/R/W	9
12	VCC +5	19 (See Note)	Y	NOT O2	
20			X	PLL TEST	
19			W	NOT R/W	
18			V	R/W	A
17	SST OUT		U	O2	
16	K6		T	AB15	F
15	DB0	22 & 21	S	AB14	3
14	DB1	Y & X	R	AB13	10
13	DB2	V & U	P	AB12	D
12	DB3	M & N	N	AB11	7
11	DB4	K & J	M	AB10	11
10	DB5	E & 5	L	AB9	T
9	DB6	B & 6	K	AB8	S
8	DB7	2 & 4	J	AB7	P
7	RST		H	AB6	R
6	NMI		F	AB5	8
5	SO		E	AB4	H
4	IRQ		D	AB3	Z
3	OI		C	AB2	L
2	RDY		B	AB1	20
1	SYNC		A	AB0	C

Jumper wires are connected 44-pin connector to 44-pin connector according to the above table. Keep wires reasonably short. (NOTE: Do not connect Pins 12 and 19 if your power supply does not have the capacity to supply an additional one ampere beyond what is used in the

rest of the system. The supply suggested in the KIM's User's Manual does not have this capacity. In this case, connect a source of +5 volts @ 1 amp to Veras Pin 19. One 309K regulator will be sufficient to supply one 4K memory board.)

Assembling the Memory Board

Only one trace must be cut on the memory board before assembly. Cut this trace, located on the component side of the board between pins 1 and 14 of IC-6. Then completely assemble the board according to its own instructions which are included in the kit. Now solder a jumper on the bottom of the board from Pin 1 of IC-6 to the hole at connector Pin A and 1. This addition of KIM R/W is necessary because the separate input and output lines had to be jumpered together when the connectors were wired.

To allow use of KIM ROM and RAM, the first add-on 4K memory board must supply a DECODE ENABLE signal. Any additional add-on boards after the first do not require the following modifications. Remember to disconnect the jumper from Pin 1 to Pin K that you have on the KIM Application Connector.

Alternative 1 — Single 4K Memory

If only one 4K memory board is to be added, the simplest derivation of the DECODE ENABLE signal is to solder a jumper from Pin 8 of IC-6 [BOARD SELECT when high] to the unused Veras edge connector Pin 13 and another jumper from this Pin 13 to the DECODE ENABLE Pin K of the KIM Application connector.

Alternative 2 — Multiple 4K Memories

To use multiple 4K memory boards, one extra chip is required. The memory board address decoding is used to turn on the KIM Decoder for Page 0 (RAM), Page 5 (Timer and I/O), Page 6 (ROM), and Page 15 (the hardwired interrupt vectors - see page 75 of KIM User's Manual). Solder jumpers from address select holes 0, 5, 6, 7, and 15 to unused edge connector pins 13, 14, 15, 16, and 17. Solder Veras connector pins 12, 13, 14, 15, 16, 17, and 19 to a 14-pin IC socket pins numbered 7, 1, 2, 13, 5, 10, and 14. Then solder IC socket pins 3 to 12, 4 to 11, and 6 to 9. Finally, solder IC Pin 8 to DECODE ENABLE Pin K of the KIM Application connector. Insert one 7408 Quad AND Gate into the socket.

Selecting Memory Page Addresses

The Veras 4K RAM memory board has jumper selection of individual 1K Pages of memory. The 4K of memory on the board does not have to be addressed in a contiguous manner. Since the documentation provided with the Veras board is a bit confusing in its discussion of the address selection, the following table is provided to simplify the task. Each Page of memory on the board has an address determined by two jump-

ers. The holes on the Veras board, and in the following table, labelled 0 to 15 select a 4K address. The holes labelled X₁, X₂, X₃, and X₄ select 1K addresses within the selected 4K region.

HOLE	X ₁	X ₂	X ₃	X ₄
0	0000	0400	0800	0C00
1	1000	1400	1800	1C00
2	2000	2400	2800	2C00
3	3000	3400	3800	3C00
4	4000	4400	4800	4C00
5	5000	5400	5800	5C00
6	6000	6400	6800	6C00
7	7000	7400	7800	7C00
8	8000	8400	8800	8C00
9	9000	9400	9800	9C00
10	A000	A400	A800	AC00
11	B000	B400	B800	BC00
12	C000	C400	C800	CC00
13	D000	D400	D800	DC00
14	E000	E400	E800	EC00
15	F000	F400	F800	FC00

A Word of Advice

While the quality of the PC Board is high, the same can not be said for the IC's. Therefore, you should not build this kit unless you are willing and able to do some limited testing to locate any defective parts. These will be replaced by the vendor at no charge. The boards do seem to work reliably once they are fully tested. To make the initial testing easier, as well as to permit simple debugging at any future time, it is suggested that all of the IC's be socketted. The vendor will supply a complete set of sockets for an additional ten dollars (\$10.00).

• • • • •

Where to Get It

The Veras 4K memory board kit is available for \$74.50 from: COMPUTER SHOP, 288 Norfolk St., Cambridge, MA 02139 617/661-2670. It may also be purchased fully socketted, assembled and tested for \$129.00 from: The COMPUTERIST, P.O. Box 3, S. Chelmsford, MA 01824 617/256-3649.

Terminal Interface Monitor (TIM)
for the 6500 Microprocessor Family

Oliver Holt
Old Nashua Road
Amherst, NH 03031

TIM is a unique monitor program for the 6500 microprocessor family. TIM is the forerunner to KIM and is still used today in many configurations — ready made and homebrew. TIM is supplied by MOS Technology on an MCS6530 multi-function chip. This chip contains ROM, RAM, an interval timer, and I/O. Using this chip, MOS Technology was able to squeeze the complete monitor function into a single IC. The 1K of ROM in the 6530 contains the monitor program; the 64 bytes of RAM are used for storage and vector interrupt addresses; the timer is used for timing the serial I/O; the 13 I/O lines are used to communicate with a serial I/O device and a parallel device. The TIM part number is MCS6530-004.

TIM has a couple of unique features not incorporated in most monitors. The first feature is the ability to reconfigure the TIM memory locations during resets. During reset all I/O lines on the 6530 are set up as inputs and look like high signals to external devices. One of these I/O lines is used with address line A15 to make A15 a "don't care" condition. 6500 type microprocessors fetch the reset vector address from FFFC and FFFD. Because A15 is a "don't care", the vector address is fetched from 7FFD instead of FFFC and FFFD. Locations 7FFC and 7FFD contain the TIM entry point for a reset condition.

Figure 1 is a block diagram of a minimum TIM-based system including the circuitry required to accomplish the reset operation. The I/O line used is PB4. This signal is inverted and NANDed with A15. During reset PB4 is high making $\overline{PB4}$ low. A low input to the NAND gate causes a high output, always enabling CS1 on the 6530. When the I/O ports are initialized in the reset service routine, PB4 goes low making $\overline{PB4}$ a high. Now the output of the NAND gate is $\overline{A15}$ and CS1 is only high when A15 is low. CS1 along with the other chip selects and the address lines give the 6530 a set of unique addresses below 8000 but the software is set up for the address space between 7000 and 73FF.

The other unique feature of the TIM is that the terminal interface speed is adaptive. After the system is reset, the user types a carriage return. TIM measures the terminal speed using the data stream generated by the carriage return signal. This speed information is stored and used as the

terminal speed for all following communication with the external device until the next time the system is reset.

After the reset and carriage return, TIM responds with an "*" and prints the contents of the registers, followed by an automatic carriage return and a ".". The period indicates that TIM is now ready to accept user commands. TIM commands allow displaying registers, executing programs, examining and altering memory, reading hexadecimal data from either a high speed reader or a TTY and writing either hexadecimal or BNPF data to a TTY. [BNPF is a tape format used by some of the older PROM programmers.]

Using the BRK instruction the user can set up breakpoints to monitor the execution of a program. The user inserts a BRK instruction [00] where the breakpoints are required. Upon execution of a BRK instruction TIM is entered and the registers are printed. The vector address for a BRK instruction is stored in RAM at FFFE and FFFF. The user may alter these locations and write his own routine for handling debug operations.

All TIM operations are performed in hex unless a BNPF tape is required. The memory is displayed in hex in groups of eight memory locations as shown:

```
.M 0000 00 01 02 03 04 05 06 07
```

command address data

TIM will respond with a period "." after each command is completed. If a user wants to modify data, he first opens memory with the "M" command and then types a colon ":" as follows: [Underlined data is what the user types.]

```
.M 0000 00 01 02 03 04 05 06 07
```

```
∴ 0000 00 01 25 03 99 (carriage return)
```

The carriage return terminates the operation. The 6500 registers may be examined:

```
.R 7052 31 27 F0 01 FF
```

```
PC P A X Y SP
```

After the registers have been opened for examination, they may be changed using the colon ":" as shown:

```
.R 7052 31 27 F0 01 FF
```

```
∴ 0100 00 00 00 00 FF (carriage return)
```

The other commands for reading and punching tapes operate in a similar manner. TIM also has a switch which is set by the "H" command that specifies whether or not a high speed reader or TTY is the source of paper tape input.

TIM, like KIM, also has many useful subroutines that can be called by a users program. A set of useable subroutines to type characters, read characters, type a line feed and carriage return, type a space, and to type a byte in hex are completely documented in the TIM manual. There are other subroutines that can be used that are not documented and these include double precision addition, output a bit, input a bit, ASCII conversion, and input eight bits.

The TIM manual contains a complete software listing and a memory test program. The manual also includes example programs to aid the user in becoming familiar with the TIM commands. TIM is a very useful building block for anyone interested in building their own 6500 system. It has been used as the monitor for a number of systems available in kit and/or assembled versions. These include the CGRS Microtech 6000 system, the DATAC 1000, and others.

If you are interested in building your own home-brew system, the figure on the following page is a block diagram for a basic system. TIM is available from MOS Technology representative.

MICRO

We're Number One !

An Editorial

We're number one in microcomputer systems. With over twelve thousand KIM-1 microcomputers in the field and a thousand per month being ordered, plus a good number of Apple I and Apple II systems, plus a variety of OSI units, plus the Jolts, Data Handlers, and other 6502-based systems, plus the huge numbers of PETs and Microminds that have been ordered, plus a lot of home-brew 6502 systems - it all adds up to a tremendous number of 6502-based microcomputer systems in use throughout the world. Adding to this number are the one and one-half million 650x chips purchased by Atari for some of their games. We've come a long way in the past year.

We're number one in microprocessor power. Microchess for the KIM-1 took 1.1K and for the 8080A took about 2.5K. Of thirty-one BASICs tested and reported in Kilobaud, the four 6502 versions placed in the top five spots, yielding only second place to the Z-80 running at 4 MHz. The 6502's many addressing modes make it very efficient and easy to program.

We're number one in user participation. Maybe there is some process of "natural selection" which attracts individuals who are industrious, able, cooperative, adventurous and communicative to the 6502. While users of other microprocessor chips have been "spoonfed" via company supported user notes and user libraries, the 6502 users have been "doing their own thing" as evidenced by the activity level of many local 6502 groups and the success of the KIM-1/6502 User Notes.

We're number one since this is our first issue. We would like to really become the most useful journal in the whole microcomputer field, not the largest, just the best. We are undertaking the venture with the conviction that there is a need for a journal to help bring all of the separate parts of the 6502 world together and with the belief that 6502 users will each do what they can to support the effort.

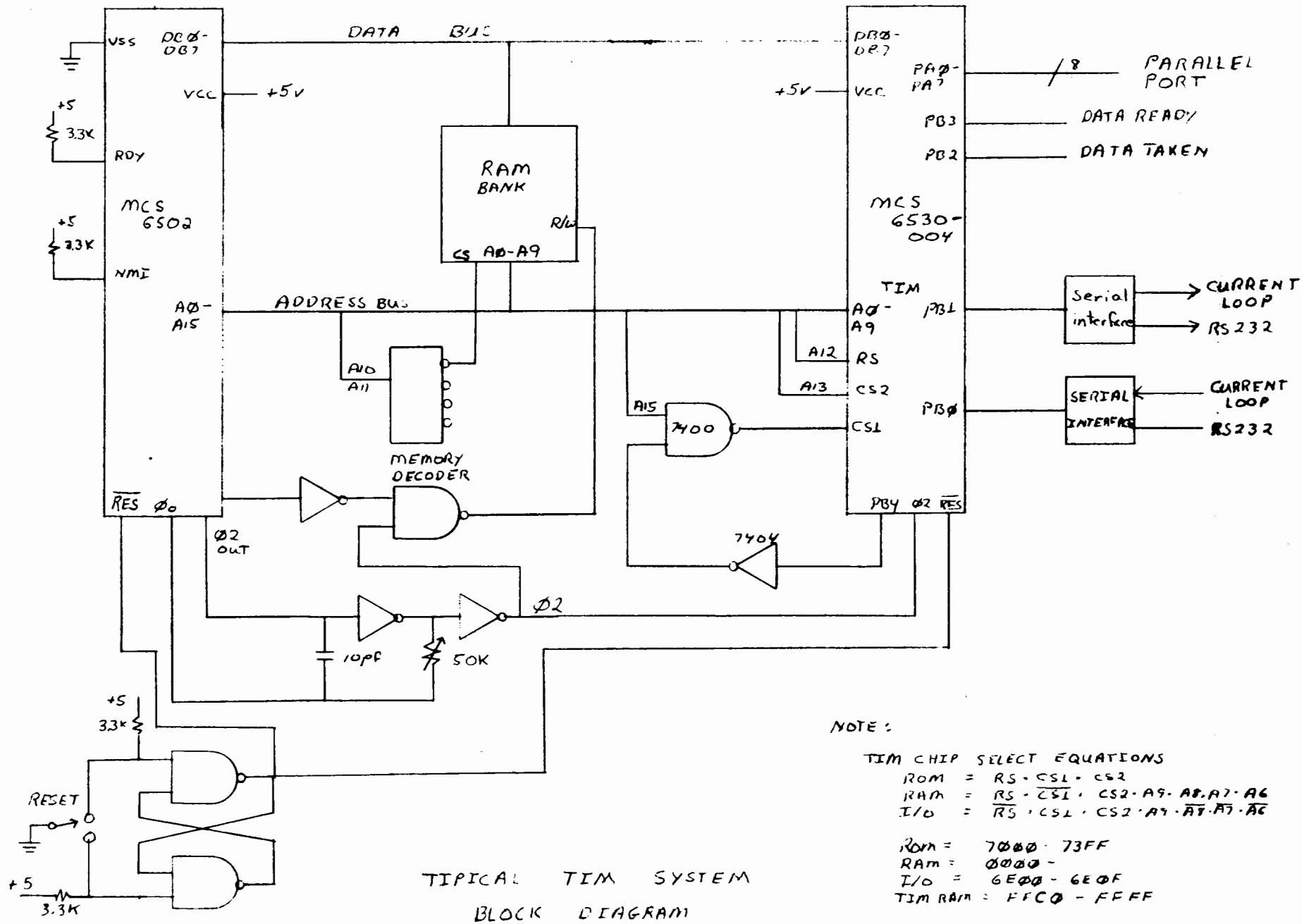

FINALLY :

6502 ON THE S100

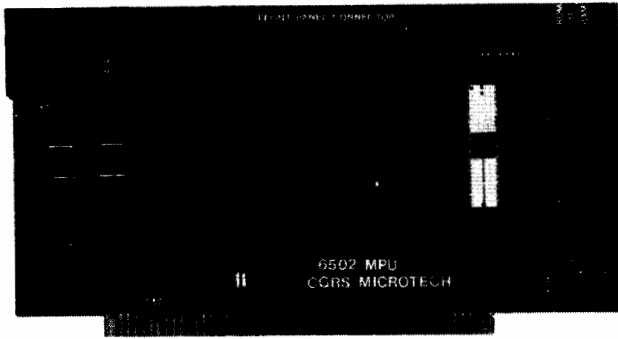

CGRS MICROTECH INTRODUCES A 6502 COMPUTER SYSTEM

- S100 STANDARD BUS COMPATIBLE
- MPU CARD WITH 2K RAM-4K ROM ONBOARD
- T.I.M. (6530) SYSTEM I/O CARD
- D.M.A. FRONT CONTROL PANEL

	KIT	ASSEM
◆ INTRODUCTORY SYSTEM		
MPU CARD: 1K RAM	\$229.95	\$299.95
FRONT PANEL: HEX DISPLAY		
◆ STANDARD SYSTEM		
MPU CARD: 1K RAM	\$329.95	\$399.95
T.I.M. I/O CARD		
S100 MOTHERBOARD: 7 SLOT		
POWER SUPPLY 5V:10A ±15V:1A		

SEND CHECK OR MONEY ORDER TO:
CGRS MICROTECH
P.O. BOX 388
SOUTHAMPTON, PA 18986

A SINGLE BOARD CONTROLLER
WITH YOUR 2K PROM OR 4K ROM PROGRAM
A FULL DEVELOPMENT SYSTEM
WITH OUR 5,120 BYTES OF ROM SOFTWARE
READY TO USE • READY TO SHIP
IN REAL-TIME INDUSTRIAL PRODUCTS

SUPER JOLT features TINY BASIC,
ASSEMBLER AND DEBUGGER ROMs on board!

ON ONE
FULLY
ASSEMBLED
AND TESTED
4 1/4" x 7" PC
CARD YOU
GET ALL:



- 8-bit 6502 processor • 1,024-byte static RAM • 32-bidirectional programmable I/O lines • 1 MHz crystal controlled clock
- interval timer • 4 interrupts, including timer and non-maskable
- 3 serial interfaces: 20 mA current loop, RS 232 and TTL • 5,120 bytes resident ROM software including a single pass symbolic assembler, a TINY BASIC and a Debug Monitor.

AVAILABLE NOW. \$375 without Assembler and TINY BASIC ROMs, \$575 with ROMs!

MICROCOMPUTER ASSOCIATES, INC.
2589 Scott Blvd., Santa Clara 95050
(408) 247-8940

KIMSI

The KIM to S-100 bus Interface/Motherboard

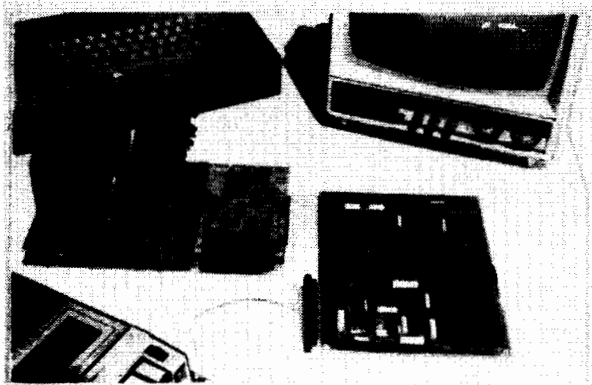

- Combines the power of the 6502 with the flexibility of the S-100 bus
- Attaches to any unmodified KIM
- Complete interface logic and fully buffered motherboard in one unit
- On-board regulation of power for KIM
- Eight slots of S-100 compatibility for additional RAM, Video and I/O boards, PROM Programmers, Speech processors . . .
- Includes all parts, sockets for ICs, one 100 pin connector, and full Assembly/Operating documentation

◆ Kit \$125, Assembled \$165

◆ All units shipped from stock



FORETHOUGHT PRODUCTS

P.O. Box 386-D
Coburg, OR 97401

(503) 485-8575

Watch for our new
KIM/Kimsi enclosure —
The "Kimsi Case"

INSIDE THE APPLE II

Arthur Ferruzzi
69 Hauman Street
Revere, MA 02151

If you've seen the colorful Apple II ads, you know that this is a fun machine. However, with a typical system price roughly equal to a trip to Europe, I suspect that the real computer nuts are going to let the wife and kids "byte" into the fun features while they make use of the Apple's extensive software and hardware power. Let's look at the Apple II as a complete, yet easily expandable, system on a board.

There's Memory

There are three rows of RAM memory sockets each of which will hold 4K or 16K bytes of dynamic RAM for a maximum of 48K bytes of RAM. There are six sockets each of which will hold 2K of ROM. Four ROMs are supplied, containing a 6K integer BASIC and a 2K System Monitor. The full feature System Monitor supports commands that examine and deposit data into memory, move and compare blocks of memory, load and store blocks on cassette, assemble and disassemble op codes, run trace and single step programs, display and modify 6502 registers, and perform hexadecimal arithmetic. In addition, the monitor is chock full of user accessible subroutines including a floating point package and a simulated 16 bit micro-processor.

One of the more interesting possibilities for the Apple II is expansion of the software in ROM. The 8K supplied is in 2K byte 9316B ROM chips. A check of the pinouts shows that these ROMs are nearly identical to the 2716/2708 EPROM. Check the manual at your nearest Apple dealer before you burn in your favorite version of PASCAL, APL, or ANIMATION.

There's Video

The second 1K block of memory is shared by the processor (during phase 2 of the clock) and the display (during phase 1 of the clock, when it is also refreshing every dynamic RAM chip on the board). Thus, the display is fast, and it is colorful. Options are 24 lines of 40 upper case characters, or 40 x 40 graphics in 15 colors plus four lines of text, or 40 x 48 graphics in 15 colors. Colors, point plotting and line plotting are also accessible from BASIC. With an 8K chunk of memory, you have high resolution 280 horizontal by 192 vertical graphics in four colors, or 32 fewer vertical lines with four lines of text at the bottom of the screen. The speed

of the video display and of the 6502 itself as well as the machine language subroutines in the monitor and available on cassette tape make the 8K graphics extremely useful.

There's I/O

First, of course, is a full typewriter style ASCII keyboard and a 1500 bits per second cassette interface. But these are only the obvious I/O devices. In addition there are four 8 bit analog inputs which measure resistance by timing a variable delay generator. Normally set up as four game paddles, you might set them up as two joysticks to control the parameters in an interactive system which provides feedback via the display. Before considering some of the I/O possibilities, it is worth noting that the Apple II has a lot of address decoding done directly on the board. For example, writing to the eight addresses C058 - C05F sets or clears four TTL output lines. Reading from addresses C061 - C063 tests three switch inputs. Further, keyboard input and strobe, cassette input and output, speaker output, paddle timers, and eight "software switches" which set the graphics and text modes, are all accessible by reading and writing specific memory locations. Thus, all ports may be set or tested by user programs including BASIC (peek and poke).

If you want to expand the system, there are eight peripheral connectors on a 50 pin (x .10") fully buffered bus. Accessing any address in the range C800 - CFFF sends an I/O strobe to pin 20 on all cards (0 through 7). Accessing addresses C1xx - C7xx sends an I/O select pulse to pin 1 on the appropriate cards (1 through 7). Accessing addresses C08x - C0Fx sends a device select pulse to pin 41 on the appropriate card (0 through 7). Thus, the 8 peripheral cards are fully decoded, saving the overhead of address decoding logic. Provision is made for daisy-chained interrupt and DMA. Presumably Apple will be supplying low cost peripherals making use of these features.

There's the Power Supply

While the peripheral bus makes it easy to design custom I/O devices, the major limitation appears to be the power supply. It is a switching type

Rockwell International and the 6502

Arthur Ferruzzi
69 Hauman Street
Revere, MA 02151

Rockwell International is now second sourcing the entire 6500 product line. One of the giants in the industry, their backing will be a big boost in gaining acceptance of the product line. Rockwell is conducting one-day FREE seminars and four-day courses on the R6500 system.

The seminar covers a lot of ground, so you should be familiar with microprocessor hardware and software in order to get maximum benefit. The presentation ties together the sometimes confusing variations in the 65xx CPU's (there are ten of them), I/O devices (four of them), and addressing modes (thirteen). The 6502 CPU is covered pin by pin and register by register, as are the PIA's and the multi-function ROM/RAM/IO Timer devices. The instructions are presented in functional groups, so that the addressing modes are related to the type of instruction. [Similar to the MICRO Programmer's Reference Card in this issue.]

Rockwell is expanding the 6500 line with SYSTEM 65, a fancy development system with built-in dual mini floppies; 16K static RAM; text editor, assembler and debug/monitor package in ROM; serial and parallel interfaces for terminal and printer; hardware breakpoint on any access of a specified location; CPU,

power supply and cabinet for \$5,000. The system bus is 86 pin Motorola Exorciser compatible, so that all you designers whose bosses bought a brand X development system can plug in a real CPU card. A PROM programmer is in the works.

Rockwell is selling 2316B and 2332 (250ns) 2K byte and 4K byte ROMs with 2708 compatible pinouts. Soon to come is a 40 pin single chip microcomputer with 2K ROM, 64 byte RAM, 2 MHz clock logic, event counter, 2 interrupt inputs and 34 I/O pins on board. Remaining pins address up to 4K of memory (more if you map memory with an I/O pin??) Separate RAM power pin can put the on-board RAM in standby mode with 30mw power dissipation. Looks like a "one chip KIM" for very small, high volume applications.

For seminar dates, contact Marketing Services, P.O. Box 3667, Anaheim, CA 92803, 714/632-3729. If you attend a seminar, be sure to mention your hobby interest and your 6502 hobby group. The Rockwell people were surprised by the high level of hobbyist activity in the Boston area. Definite "good guys" you might meet are Joe Nissim from the Anaheim office and Dick Montana from the East Coast Tech Center, North Brunswick NJ. 08902.

MICRO

(Inside the Apple II — continued)

supply where the AC is rectified and sent to an oscillator whose frequency varies with the load so that the +5 volt DC line is never more than 3% off. The other voltages basically respond to the loading on the +5 volt line and are not as well regulated. I/O cards should draw less than 1.5 watts and the power cord MUST BE VERY WELL GROUNDED.

The Bottom Line

In terms of serious applications, here is what you get: a fast 6502 microprocessor with all of its inherent features, 4 to 48K of RAM, a fast 6K integer BASIC in ROM, a classy 2K System Monitor in ROM, a "transparent" 1K color video with graphics, 8K color graphics, an ASCII keyboard with interface, four analog inputs, a fast cassette interface, three digital I/O

bits, an audio "beeper", eight decoded peripheral connectors, a stylish package, and a (small) power supply.

Just add up what all that good stuff costs separately. Then, if your application falls within or near these specifications, the Apple II will be a better buy than a homebrew system. In shopping for a computer, remember to try before you buy, from a reputable dealer. The Apple II is up and running at many computer stores across the country. (For the dealer nearest you, see the dealer list on page 16 of the October 1977 issue of BYTE, or write to Apple Computer Inc., 20863 Stevens Creek Boulevard, Cupertino, CA 95014. With a little savvy and careful picking, we can have the fine products we want and put the squeeze on the lemons.

The PET's IEEE-488 Bus: Blessing or Curse?

Charles Floto
267 Willow Street
New Haven, CT 06511

Copyright 1977 by Charles Floto

IEEE-488 (usually pronounced I-triple-E four-eighty-eight) is the number of a standard for information exchange adopted by the Institute of Electrical and Electronics Engineers. Given that a major complaint of microcomputer users has been that the lack of industry standards prevents the exchange of information, the reaction when it was announced that Commodore's PET 2001 would support the IEEE bus should perhaps not be surprising.

However a few people have been surprised by this 488 mania. Pickles & Trout accompanied announcement of an I/O board for the S-100 bus with the offhand remark that they planned to produce a 488 adapter for it. When they found that enthusiasm for this incidental feature overwhelmed interest in the basic board they decided to develop an I/O card exclusively to support the IEEE-488 bus. It is expected to retail in the \$200 range. Which makes the fact that Commodore is including a similar interface in the \$800 PET (8K RAM version) all the more wonderful.

Just how easy will it be for a PET owner to design a system around the IEEE-488 bus? It can be compared to solving the following problem: You are to design a computer with provision for more than one CPU card. Its bus shall be limited to 16 signal lines, with several ground lines but no power lines. You are to build a separate power supply for each card in the system and, since it is to be spread all over your home or office, a separate case as well.

The difference between this problem and using the IEEE-488 bus is that in the latter case the design of the bus has been done for you and to use it you must be prepared to abide by certain specified and rather complex conventions. In short, you shouldn't even attempt to design a peripheral interface to the PET's 488 I/O bus unless you feel capable of designing internal circuit cards for other computers. Even then you may have problems if all your experience has been with a bus each of whose lines has a fixed purpose, rather than some being shared between data and either address or control functions.

If the IEEE-488 bus presents such difficulty in designing peripherals, why would Commodore want to us it? The first thing to realize is that design represents a fixed cost, the same whether you build one unit or 100,000. While design cost per unit is absurdly exorbitant for the individual making a single 488-compatible component, it becomes trivial for the mass producer.

For a second consideration suppose you were putting together your own system and Pickles & Trout offered you a circuit card to link your computer to the IEEE bus for \$200. That's a lot to pay for one I/O port, but it's a bargain if it's the only one you'll ever have to buy. Thus the IEEE-488 format makes the PET less expensive than including an impressive number of serial and parallel ports.

Third, why expect PET to make things easy for individual hardware designers when that isn't the market it's aimed at?

At this point perhaps it's worth noting that the PET is only claimed to be electrically and logically compatible with the IEEE-488 bus--physical compatibility is lacking as signals come out on printed circuit fingers rather than the standard connector. Standard interconnection cable consists of 16 signal lines, seven grounds, and a shield; it has male and female connections at each end. The corporate purchaser of a large system might pay as much for a single cable as the hobbyist pays for a circuit card.

We can't really judge the value of the PET's IEEE-488 bus until we see what becomes available to connect to it, and at what price. For now we may conclude that it presents a problem to those who want to design their own peripherals, but the potential for a competitive market in sophisticated mass-produced peripherals which will 'plug in and go' in a wide variety of systems. And those who already own IEEE-488 products will be able to add the PET's computer power at an unprecedented price.

6502 RELATED COMPANIES

APPLE COMPUTER COMPANY, 20863 Stevens Creek Blvd., B3-C, Cupertino, CA 95104
 ARESCO, 314 Second Avenue, Haddon Hts., NJ 08035, 609/546-7491 (Nights)
 KIM/TIM High-Level Software
 CGRS MICROTECH, INC., P.O. Box 368, Southampton, PA 18966, 215/757-0284
 6530-004 Terminal Interface Monitor on the S100 Bus (TIM)
 With a 6520 PIA on board 24 parallel I/O lines - RS232 serial port or
 20MA current loop - DMA - Control Panel with Hexadecimal Data & Address
 Display - Single Step/Debug Mode - Preset Button to start up - Vector
 S100 Mother Board
 COMMODORE BUSINESS MACHINES, 901 California Avenue, Palo Alto, CA 94304
 The COMPUTERIST, P.O. Box 3, S Chelmsford, MA 01824, 617/256-3649
 KIM Games and Application Software; Power Supply, Memory, Relays
 DATAC ENGINEERING, P.O. Box 406, Southampton, PA 18966
 ECD CORPORATION, 196 Broadway, Cambridge, MA 02139
 ELECTRO-DATA POWER, 1306 Brielle Avenue, Orange, CA 92667
 ELECTRONIC TOOL, 4736 El Segundo Blvd., Hawthorne, CA 90250
 THE ENCLOSURES GROUP, 55 Stevenson St., San Francisco, CA 94105, 415/495-6925
 Enclosures - Standard (Including KIM-1) and Custom
 F & D ASSOCIATES, P.O. Box 183, New Plymouth, OH 45654
 SS50 Bus products including a 6502 CPU Board
 FORETHOUGHT PRODUCTS, P.O. Box 386-D, Coburg, OR 97401, 503/485-8575
 KIM to S-100 Interface/Motherboard
 ITTY-BITTY COMPUTERS, P.O. Box 23189, San Jose, CA 95153
 KL POWER SUPPLIES, P.O. Box 86, Montgomeryville, PA 18936, 215/257-8195
 4.5amp KIM Power Supply; other computer power supplies
 Kenneth Ensele, 1337 Foster Road, Napa, CA 94558
 KIM-1/650X USER NOTES, 109 Centre Avenue, West Norriton, PA 19401
 MICRO-SOFTWARE SPECIALISTS, INC., 1911 Meadow Lane, Arlington, TX 76010
 Assembler/Text Editor and other software 817/274-0291
 Assorted systems software for any 6502 (by changing three jumps).
 Assembler/Text Editor, Disassembler, others.
 Commented source listings. Hard copy \$20.00 for all. Paper tape/
 cassette extra. Texans, 5% tax. VISA, Mastercharge. Expires 12/31/77.
 MICRO-WARE LIMITED, 27 Firstbrooke Road, Toronto, Ontario, CANADA M4E 2L2
 MICROCOMPUTER ASSOCIATES INC., 2589 Scott Blvd., Santa Clara, CA 95050
 Super JOLT; Resident Assembler, Tiny BASIC ROMs; 408/247-8940
 4K RAM; 2K PROM; Audio Cassette Interface; power supply; card cage.
 Universal card; software: monitor, assembler, editor, Tiny BASIC.
 SOON----8K/16K PROM, 2708/2716 Intel & TI PROM programmer, floppy
 disk interface. OEM Specialists---Custom Specialists.
 MICROFIT SYSTEMS, 1595-21 Laurelwood Road, Santa Clara, CA 95050
 MOS TECHNOLOGY, INC., 950 Rittenhouse Road, Norristown, PA 19401
 OHIO SCIENTIFIC INSTRUMENTS, 11679 Hayden, Hiram, OH 44234
 PAIA ELECTRONICS, P.O. Box 14539, Oklahoma City, OK 37114
 PYRAMID DATA SYSTEMS, 6 Terrace Avenue, New Egypt, NJ 08533
 "XIM" - 1K monitor for KIM-1. 609/758-7487
 "XIM" - a TTY command oriented, software aid for KIM-1; Fits in 1K.
 Adds 17 commands to present KIM monitor. Relocatable and ROM-able.
 Includes four user-defined commands; 45-page manual. \$12.00 manual
 & cassette; \$10.00 papertape version. Resides at 2000 HEX.
 RIVERSIDE ELECTRONICS DESIGN, 1700 Niagara Street, Buffalo, NY 14207
 SCARPA LABORATORIES, INC., 46 Liberty Street, Metuchen, NJ 08840
 SWTPc type back planes (7 slots) 201/549-4260
 6502 PROGRAM EXCHANGE, 2920 Moana, Reno, NV 89509
 TECHNICAL SYSTEM CONSULTANTS, INC, P.O. Box 2574, W. Lafayette, IN 47906

HYPERTAPE and ULTRATAPE

Robert M. Tripp
8 Fourth Lane
S. Chelmsford, MA 01824

While the cassette tape I/O of the KIM-1 is one of its best features, it is terribly slow. Waiting a couple of minutes to load a 1K program can be a real pain. Jim Butterfield showed how to speed up the tape process by writing KIM compatible tapes which were up to six times as fast as the normal KIM ["Supertape!", KIM-1 User Notes, Vol. 1, Issue 2, Page 12, or "Hypertape", The First Book of KIM, Page 119]. For the COMPUTERIST HELP packages - Editor, Mailing List, and Information Retrieval - I doubled this rate by writing a byte of data as a byte, not converting it into two ASCII characters. This "Ultratape" is not KIM compatible and requires a special loading program. The DUMP routine presented here combines both Hypertape and Ultratape. The LOAD routine is used to load an Ultratape. These two routines, as presented here, assume that your system has a means of turning the cassette tape units on and off under program control. [See "Computer Controlled Relays" in this issue.]

Dumping Hypertape

Eight locations in page zero are used to hold the arguments for DUMP. For Hypertape they are:

00D8 Select Hypertape Mode 02
00D9 Program Identification No. [ID] 01-FE
00DA Starting Address Low [SAL]
00DB Starting Address High [SAH]
00DC Low Memory Address of Data
00DD High Memory Address of Data
00DE Low Count of Bytes to Dump
00DF High Count of Bytes to Dump

A feature of this version of Hypertape is that the data to be dumped does not have to reside in its normal memory locations. The Starting Address stored on the tape is provided by 00DA and 00DB independently from the actual memory address which is provided by 00DC and 00DD.

Four additional locations are used on page zero to control the rate at which the data is dumped.

00E8 3700 Hz Speed Control 02 = 6X
[04 = 3X, 06 = 2X, 0C = 1X]
00E9 3700 Hz Pulse Duration
00EA 2400 Hz Speed Control 03 = 6X
[06 = 3X, 09 = 2X, 12 = 1X]
00EB 2400 Hz Pulse Duration

Locations 00EC and 00ED are used for temporary storage. Note that you must change the values of both 00E8 and 00EA to change the dump speed to three, two, or one times the normal KIM dump rate.

DUMP starts at location 0120. The first instruction is a subroutine call to turn on the cassette unit via a relay. If your system is not equipped for automatic control of the cassette, then simply put NOP's in place of this instruction [EA, EA,EA] and the matching subroutine call at location 01A0. The two NOP's at 0123 replace an instruction that was used in the HELP version but which is not required generally. Location 01A6 is the end of the DUMP. This may be either a JMP instruction (as shown) or can be an RTS instruction if DUMP is called as a subroutine.

Hypertape Format

Hypertape uses the standard KIM cassette tape format.

100 SYNCs/Start of Header/ID/SAL/SAH/
2 ASCII characters for each byte of data .../
Terminator / CHKL / CHKH / EOT / EOT

SYNC is the ASCII SYNC character = 16 hex
Start of Header is the ASCII * = 2A hex
ID is the Program Identification Number = 01 to FE hex

SAL and SAH are the Start Address Low and Start Address High which are used by the KIM Loader.

Each byte of data is converted into two ASCII characters such that a 3F would be stored as ASCII 3 [33] and ASCII F [46]

The Terminator is an ASCII / = 2F hex
CHKL and CHKH are the Check Digit Low and Check Digit High which are generated by the KIM CHKT subroutine during the DUMP and are tested during the LOAD routine.

EOT is the ASCII character = 04 hex

Loading Hypertape

Since Hypertape is KIM compatible, all you need to load it is the standard KIM Monitor load routine. Set your arguments in 17F5 through 17F9, make sure that the status bits in 00F1 are zero, and start the loader at 1873. That's all there is to it.

HYPERTAPE / ULTRATAPE

Dump Routine

```

0120 20 52 02 DUMP JSR TWRITE TURN ON RECORDER
0123 E6 E4 INCZ STEPNO BUMP OVER PARAMETERS
0125 A5 DC LDAZ PARAM4 LOW MEMORY ADDRESS
0127 8D 5D 01 STA LOW SAVE AS POINTER
012A A5 DD LDAZ PARAM5 HIGH MEMORY ADDRESS
012C 8D 5E 01 STA HIGH SAVE AS POINTER
012F 20 43 19 JSR INTCHK INIT CHECK DIGITS
0132 A9 BF LDAIM BF SET UP TAPE OUTPUT
0134 8D 43 17 STA PBDD
0137 A9 27 LDAIM 27
0139 85 ED STAZ GANG
013B A9 64 LDAIM NSYNCS GET NUMBER OF SYNCS
013D 85 EC STAZ COUNT SET SYNC COUNTER
013F 20 AC 01 SYNC LDAIM SYNC OUTPUT SYNCS
0141 20 C0 01 JSR OUTCHR AS CHARACTERS
0144 C6 EC DECZ COUNT DEC AND TEST SYNC
0146 D0 F7 BNE SYNGS COUNTER UNTIL DONE
****
0148 A9 2A HEADER LDAIM ** START OF HEADER
014A 20 C0 01 JSR OUTCHR CHARACTER
014D A5 D9 LDAZ PARAM1 ID NUMBER
014F 20 AC 01 JSR OUTBT OUTPUT BYTE, NO CHECK
0152 A5 DA LDAZ PARAM2 SAL OR CNTLO
0154 20 A9 01 JSR OUTBTC OUTPUT BYTE WITH CHECK
0157 A5 DB LDAZ PARAM3 SAH OR CNTHI
0159 20 A9 01 JSR OUTBTC OUTPUT BYTE WITH CHECK
****
015C AD 00 00 DUMPIT LDA [LOW,HIGH] DATA POINTER
015F EE 5D 01 INC LOW BUMP DATA POINTER
0162 D0 03 BNE CHECK
0164 EE 5E 01 INC HIGH
0167 20 4C 19 CHECK JSR CHKT KIM CHECK SUM ROUTINE
016A A6 EC LDXZ COUNT FIRST BYTE TEST
016C F0 0A BEQ FIRST USE KDUMP FOR FIRST BYTE
016E A6 D8 LDXZ PARAMO TEST DUMP OR KIM DUMP
0170 CA DEX DUMP = 1
0171 D0 07 BNE KDUMP KDUMP = 2
0173 20 C0 01 JSR OUTCHR 1 BYTE/CHARACTER
0176 F0 05 BEQ TEST UNCONDITIONAL BRANCH
0178 E6 EC FIRST INCZ COUNT ONLY FIRST ONCE
017A 20 AC 01 KDUMP JSR OUTBT 2 BYTES/CHARACTER
017D C6 DE TEST DECZ CNTLO COUNT DATA OUTPUT
017F D0 DB BNE DUMPIT CONTINUE
0181 C6 DF DECZ CNTHI
0183 30 02 BMI TRAIL DONE IF MINUS
0185 D0 D5 BNE DUMPIT CONTINUE IF NOT ZERO
****

```

```

0187 A9 2F TRAIL LDAIM "/ TERMINATOR CHARACTER
0189 20 C0 01 JSR OUTCHR OUTPUT AS CHARACTER
018C AD E7 17 LDA CHKL WRITE CHECK CHARACTERS
018F 20 AC 01 JSR OUTBT AS BYTE WITHOUT CHECK
0192 AD E8 17 LDA CHKH
0195 20 AC 01 JSR OUTBT
0198 A9 04 LDAIM EOT END OF TRANSMISSION
019A 20 C0 01 JSR OUTCHR WRITE EOT TWICE
019D 20 C0 01 JSR OUTCHR TO END DUMP
01A0 20 52 02 JSR TWRITE TURN RECORDER OFF
01A3 20 8C 1E JSR INIT1 RE-INIT THINGS
01A6 4C 04 03 JMP NXTSTP CONTINUE HELP
****
01A9 20 4C 19 OUTBTC JSR CHKT KIM CHECK SUM
01AC 48 OUTBT PHA SAVE DATA ON STACK
01AD 4A LSRA SHIFT DATA TO GET
01AE 4A LSRA MOST SIGNIFICANT CHAR.
01AF 4A LSRA
01B0 4A LSRA
01B1 20 B5 01 JSR HEXOUT OUTPUT AS HEX CHARACTER
01B4 68 PLA RESTORE DATA
01B5 29 0F HEXOUT ANDIM OF MASK DATA TO HALF BYTE
01B7 C9 0A CMPIM OA CONVERT TO ASCII
01B9 18 CLC
01BA 30 02 BMI HEX2
01BC 69 07 ADCIM 07 A - F CHARACTER
01BE 69 30 HEX2 ADCIM 30 0 - 9 CHARACTERS
****
01C0 A2 08 OUTCHR LDXIM 8 OUTPUT 8 BITS
01C2 86 DC STXZ COUNTR
01C4 A2 02 TRY LDXIM 2 TABLE POINTER
01C6 86 DD STXZ TRIB
01C8 B4 E8 ZON LDYXZ NPUL NUMBER OF PULSES
01CA 48 PHA SAVE DATA
01CB 2C 47 17 ZON1 BIT CLKRDI WAIT FOR READY
01CE 10 FB BPL ZON1
01D0 B5 E9 LDAZX TIMG GET TIMING VALUE
01D2 8D 44 17 STA CLKIT SET TIMER
01D5 A5 ED LDAZ GANG GET CURRENT STATE
01D7 49 80 EORIM 80 FLIP TAPE BIT
01D9 8D 42 17 STA SAD OUTPUT STATUS
01DC 85 ED STAZ GANG SAVE STATUS FOR LATER
01DE 88 DEY DEC COUNTER
01DF D0 EA BNE ZON1
01E1 68 PLA RESTORE DATA
01E2 C6 DD DECZ TRIB LOOP TEST
01E4 F0 05 BEQ SETZ THIRD SEGMENT?
01E6 30 07 BMI ROUT CURRENT BIT DONE?
01E8 4A LSRA SHIFT FOR NEXT BIT
01E9 90 DD BCC ZON OUTPUT 1 IF SET
01EB A2 00 SETZ LDXIM 0 OUTPUT ZERO
01ED F0 D9 BEQ ZON UNCONDITIONAL BRANCH
01EF C6 DC DECZ COUNTR BIT COUNTER
01F1 D0 D1 BNE TRY MORE TO DO
01F3 60 RTS THIS BYTE IS DONE
****

```

MIGRO

1:14

Dumping Ultratape

The same eight page zero locations that were used to hold the arguments for the Hypertape DUMP are used for the Ultratape DUMP, but 00DA and 00DB have a different usage.

00D8	Select Ultratape Mode	01
00D9	Program Identification Number	01-FE
00DA	Low Count of Bytes Dumped	
00DB	High Count of Bytes Dumped	
00DC	Low Memory Address of Data	
00DD	High Memory Address of Data	
00DE	Low Count of Bytes to Dump	
00DF	High Count of Bytes to Dump	

The Ultratape Routine produces a tape that is not compatible with the KIM Monitor. The basic difference is that it stores a byte of data directly without converting it into two ASCII characters. This results in a two-to-one data compression over the KIM method. Since any data value is valid, there must be some way to determine how much data there is in a record. The Terminator character (/ = 2F) cannot be used since there is no way to distinguish between it and a 2F hex data byte. The problem is solved by putting a count of the number of data bytes into the Header of the tape record. Since the LOAD routine will provide the Starting Address information, the SAL and SAH bytes are not needed. Ultratape uses these two positions in the header to store a two byte count which will be used by LOAD to know how many bytes of data to load. Because the LOAD routine uses a portion of the KIM Monitor to get into sync, to test the Program ID, and to pick up the header information (two byte counter), and does not regain control until after the first byte of data has been picked up and packed by the KIM, the first data byte of Ultratape is actually stored as two ASCII characters, just as in Hypertape. All other data bytes are stored without conversion. A Terminator character follows the last valid data byte so that LOAD can test it and make sure it has not missed or added a character. The remainder of the Header and Trailer are identical to the KIM standard.

100 SYNCs / Start of Header / ID / Count Low / Count High / 2 ASCII characters for the first data byte / one byte for each data byte . . . / terminator / CHKL / CHKH / EOT / EOT

Loading Ultratape

Since Ultratape is not KIM compatible, it requires a special LOAD routine. The LOAD routine uses four locations in page zero to hold its arguments:

00D8	Select Load Function	00
00D9	Program Identification Number	01-FE
00DA	Starting Address Low	
00DB	Starting Address High	

[00DC is used internally by LOAD]

Locations 00E8 to 00EB which were required to set the speed in the dump routines are not required for LOAD. LOAD starts at 0200 with a subroutine call to the routine to turn on the cassette under program control. This should be NOP'ed if you do not have your cassettes under program control. Similarly the call at location 024C should be NOP'ed. Since it is possible to get and detect an error during a LOAD, there must be some way to signal this back to the calling routine. In the HELP programs which this code comes from, a location called STEPNO is incremented on good loads and not incremented on bad loads via the instruction at location 024A. To make LOAD a more general subroutine you can change this to increment location 00D8 which should be set to zero before calling LOAD. Then upon return from LOAD this location can be tested and some action taken if an error has occurred. Location 024F is the end of LOAD. It may be either a JMP instruction (as shown) or can be an RTS instruction if LOAD is called as a subroutine.

In addition to being faster than loading via the KIM monitor, LOAD has the feature that when the load is complete control returns to the user program, not the KIM Monitor. This makes it possible to load data from the cassette under program control without ending up in the KIM Monitor with location 0000 staring you in the face. The data loaded may be ASCII data as in the HELP programs, or may be program data that is overlaying part of the RAM under program control. This feature considerably expands the usefulness of the KIM cassette interface.

Cassette On/Off Routines

TWRITE at 0252 toggles the direction bit for PB1. This turns a relay on and off on successive calls. DUMP calls TWRITE to control the WRITE cassette. TREAD at 0256 toggles the direction bit for PB0 to control the action of a second relay. TREAD is called by LOAD to control the READ cassette unit.

LOAD ULTRATAPE

0200	20 56 02	LOAD	JSR	TREAD	TURN ON RECORDER
0203	A5 D9		LDAZ	PARAM1	GET TAPE ID NUMBER
0205	8D F9 17		STA	ID	STORE FOR KIM LOADER
0208	A9 60		LDAIM	RTS	SET RETURN INSTRUCTION
020A	85 DC		STAZ	PARAM4	HELP POINTER ROUTINE
020C	20 75 16		JSR	INTCHK	INIT CHECK SUM

020F	A2 8D	RETURN	LDXIM	STA	ON RETURN FROM KIM
0211	86 D9		STXZ	PARAM1	CREATE STORE ROUTINE
0213	D0 09		BNE	GET1	FIRST CHAR. IS PACKED
0215	20 24 1A	GET	JSR	RDCHT	READ NEXT CHARACTER
0218	AD EA 17		LDA	SAVX+1	GET "RAW" CHARACTER
021B	20 4C 19		JSR	CHKT	USE KIM CHECK SUM
021E	20 D9 00	GET1	JSR	PARAM1	STORE CHAR ROUTINE
0221	E6 DA		INCZ	PARAM2	BUMP LOW POINTER
0223	D0 02		BNE	GET2	TEST LOW POINTER
0225	E6 DB		INCZ	PARAM3	BUMP HIGH POINTER
0227	CE ED 17	GET2	DEC	CNULO	VEB+1 = CNTLO
022A	D0 E9		BNE	GET	GET NEXT CHARACTER
022C	CE EE 17		DEC	CNIHI	VEB+2 = CNTH1
022F	30 02		BMI	ENDTST	DONE IF MINUS OR ZERO
0231	D0 E2		BNE	GET	MORE IF GREATER THAN 0

0233	20 24 1A	ENDTST	JSR	RDCHT	READ TERMINATOR CHAR.
0236	C9 2F		CMPIM	"/	SHOULD BE SLASH
0238	D0 12		BNE	ERROR	ELSE COUNTING ERROR
023A	20 F3 19		JSR	RDBYT	GET LOW CHECK DIGIT
023D	CD E7 17		CMP	CHKL	IS IT CORRECT?
0240	D0 0A		BNE	ERROR	ELSE DATA ERROR
0242	20 F3 19		JSR	RDBYT	GET HIGH CHECK DIGIT
0245	CD E6 17		CMP	CHKH	IS IT CORRECT?
0248	D0 02		BNE	ERROR	ELSE DATA ERROR
024A	E6 E4		INCZ	STEPNO	BUMP STEP ON GOOD LOAD
024C	20 56 02	ERROR	JSR	TREAD	TURN TAPE RECORDER OFF
024F	4C 04 03		JMP	NXTSTP	CONTINUE PROGRAM

0252	A9 02	TWRITE	LDAIM	2	TOGGLE BIT 2 FOR WRITE
0254	10 02		BPL	TAPE	UNCONDITIONAL BRANCH
0256	A9 01	TREAD	LDAIM	1	TOGGLE BIT 1 FOR READ
0258	4D 03 17	TAPE	EOR	1703	TOGGLE APPROPRIATE BIT
025B	8D 03 17		STA	1703	PBO = READ/PB1 = WRITE
025E	60		RTS		

1:16

MIGRO

MICRO is published bi-monthly and costs \$1.50 per issue or \$6.00 per year (six issues). The first issue was OCT/NOV 1977. Foreign subscriptions, please write for rates.

- Please enter my subscription for one year - \$6.00 enclosed.
 Please send me a copy of the first issue [OCT/NOV] - \$1.50.

NAME:
 ADDR:
 CITY: STATE: ZIP:

- Please include my name and address in mailing lists that you make available to dealers, suppliers, and other legitimate 6502 interests so that I may be kept informed of new products, current developments, and so forth.

- Please DO NOT include my name and address in mailing lists that you make available to any outside sources.

Check appropriate boxes above and send your check to:

MICRO, P.O. Box 3, S Chelmsford, MA 01824, U.S.A.

MIGRO

KIM-Based Degree Day Dispatcher

Hundley Controls Inc.
183 Columbia Road
Hanover, MA 02339
617/826-5019

Reported by Mike Rowe

Hundley Controls is building a number of different KIM-based microcomputer systems to be used primarily by fuel oil dealers to perform a variety of functions such as basic accounting, meter ticket printing, and so forth. Some of their systems are fairly complex and include video or hardcopy terminals, floppy disks, and other accessory devices. While these systems are interesting, they are not that much different from other small business systems. One portion of their system, however, is a rather unique and rich use of a KIM. An integral part of all the Hundley systems is the capability to automatically sample the outside temperature and to calculate "degree day" values which are used by fuel oil dealers to determine when to make oil deliveries. The module called the "Degree Day Dispatching Computer" or "3DC" performs this function and may be used as a stand-alone system.

What the Degree Day Dispatcher Does

The Degree Day Dispatching Computer (3DC) is the first low cost computer for automatic degree day dispatching. The 3DC is more than a local temperature monitoring device. It actually automates the widely adopted degree day dispatching system being used by today's fuel oil dealer. Besides temperature, the 3DC functions automatically on a mini customer master file and produces a daily list of customer deliveries showing customer number, gallons per customer, zone and status. Each day's activity is routed by zones and is automatically assigned to prescribed truck capacity and run patterns. The listing also shows gallons per truck run, number of customers per run, truck number and run number.

The 3DC is programmed to function automatically on a customer file comprised of delivery zone, tank size, hot water code, last fill date, usage factor (K) and status code; a dealer file comprised of truck numbers, capacities and number of runs per day/per truck; and a temperature profile comprised of period to date mean temperatures. The user has the option of complete automatic operation, or he can, when desired, interact with the system to find the best daily run pattern for his particular day.

Local Temperature Monitoring - Local temperature is automatically monitored on the hour, 24 hours per day. A noon mean is calculated and

stored for degree day dispatching. When a degree day dispatching run is made by the 3DC, the last 48 hour mean is projected up to the following noon, accounting for the usable degree days up to the assumed delivery time (noon).

Degree Day Dispatching - A modeling capability is present within this function, allowing the modeling of the delivery patterns of various tank reserves. The remaining reserve of each customer is determined each time the degree dispatching run is processed. The results are compared to a user selected threshold value. If the reserve is less than, or equal to the threshold, the customer record is selected for delivery. After the printout is complete, the user can simply change the threshold value (raise or lower it) and repeat the process. The next list will show additional deliveries (raised threshold), or fewer deliveries (lower threshold). In this way, it is possible to tailor the day's deliveries to the day's requirements. For example, if a truck is disabled and can not deliver on a particular day the threshold can be lowered, resulting in a reduced number of deliveries for that day. The key benefit of the 3DC system is speed - a number of different run schemes can be produced in a matter of minutes and the best run selected for implementation. The whole picture is on a printed list, all neatly laid out by delivery zone, truck number, truck run, and customer number.

Forecasting - This function will show the deliveries for the upcoming period, based on the last 48 hour mean, or for any user specified mean. For example, the 3DC will show the deliveries for the next 14 days for customers with a reserve on the day of any value. Precise planning is facilitated by this valuable feature.

Truck Routing - The dealer masterfile which is stored by the 3DC is used to customize the scheduled deliveries to the company's truck capacities and run patterns. Customers are loaded by zone, and gallons required per customer, within a truck run, are based on the truck's capacity. Once capacity is reached, the truck run is ended. A sixteen zone matrix, and loading customers by zone or contiguous zone, optimizes the truck's run efficiency. A truck is scheduled for its customary number of daily runs. This may be easily changed if required: if a truck breaks down or a driver is sick.

Inquiry Capability - It is possible to inquire into the 3DC to determine the delivery status of any customer. By simply keying the customer number, an entry showing the customer number, zone, and amount of fuel his tank will accept is printed. Also shown is the number of days until the next scheduled delivery based on the last 48 hour mean. This feature assists in reducing unnecessary and costly fuel deliveries.

The KIM-based System

To do all of the above functions requires a rather large system. Right? Or, wrong? Well, decide for yourself. The Hundley Controls 3DC System hardware consists of a KIM-1, 8K RAM, a temperature sensing device of their design, and a small, numeric only printer, plus a power supply with battery backup and a case that holds the entire system. And that's all. No on-line cassettes or floppy disk. No ASCII terminal or video display. Nothing very fancy. The key to the system is making full use of the KIM's capabilities and keeping the master files in the 8K RAM.

Almost all of the KIM's basic features are utilized in this system. Of course, the 6502 microprocessor is the brains of the operation. All software is written in assembly or machine level code. Some of the KIM Monitor subroutines on the 6530 chips are used for the actual operational system, and the KIM Monitor is used extensively during the system start-up and debugging stages. The KIM Keypad and Display are the primary input and output devices. Through these two devices the operator keys in his requests, supplies new data, and interacts with the programs. Since the system is time dependent, making temperature measurements every hour, the 6530's Interval Timer is used as the master clock for the system. While the KIM Cassette I/O is not part of the functioning 3DC System, it is used to initially load the system, and may be used to "failsafe" the master files. These files may be dumped to cassette tape via the KIM Monitor to permit recovery in the event of a catastrophic system failure. The KIM Terminal I/O is also not used in the 3DC System, but was used during development, and could be used to directly enter information into the system memory if the user has any type of serial terminal. The 6530 I/O capabilities are used to input data from the temperature sensing device and

to output numeric and control data to an inexpensive printing calculator which provides the system with a cheap hardcopy mechanism. The ability of the KIM system to be easily expanded permits the addition of the 8K RAM which is required to hold the system programs and data base. The system designers found that the "spread-out" organization of the KIM made it easier to use and to interface to than some other 6502 based systems they had considered for this application.

The key to the system is, of course, the software. A second key is, however, the idea of keeping all of the data files in a compact form in the 8K RAM, with battery backup to prevent the loss of data through external power failure. This eliminated the need for more expensive I/O devices and software to operate them. While there are limitations to the amount of data you can have online with this system, as configured it can hold 600 customer records in memory plus the complete software package to run the system.

Summary

We see here a reasonably complex set of functions - degree day dispatching - being performed by a KIM-1 with some additional memory, a temperature sensing device and a cheap numeric printer. This 3DC System may be used as a complete stand-alone unit, or may be one module of a more complex system developed by Hundley Controls which includes floppy disks, and a terminal, and which performs a large number of additional functions for the fuel oil dealer. Since the 3DC is a module of the larger Fuel Oil System, a dealer can start small and then add the advanced capabilities at a later date with the original equipment becoming part of the enlarged system. The operator does not have to relearn or retrain on the portion of the system he has already mastered.

The 3DC Degree Day Dispatching Computer with all of the features discussed above costs \$2990. The larger Fuel Oil System which includes the 3DC, an ASCII hardcopy terminal, floppy disks and comes in an integrated desk unit costs \$9990. This unit supports Accounts Receivable, Meter Ticket Printing, and Ledger Card Maintenance.



hundley controls, inc.

Conway Building - Route 53 at 139
183 Columbia Road
Hanover, Massachusetts 02339
Telephone (617) 826-5019

THE COMPUTERIST

The HELP Relay Package consists of the components required to connect your KIM-1 to two cassette tape recorders with REMOTE On/Off jacks to enable the cassettes to be turned ON and OFF under program control. You should connect the components together following the circuit diagram. A PC type card can be used for mounting the components. A variety of sizes are available through your local Radio Shack or similar type of store.



The KIM-1 circuitry is such that during a READ operation a signal is present on the AUDIO OUT LO line. This can cause a problem on those tape recorders whose electronics are not turned off when held in the REMOTE state since the record head is active and the signal being generated by the READ will be written on the tape. This can wipe out good data on the tape. The solution is provided by the third relay which is placed in parallel with the WRITE Cassette REMOTE relay and controls the AUDIO OUT LO line. The record head is now active only when the WRITE cassette has been selected, and is otherwise disconnected and inactive. You will wish to bring the AUDIO OUT LO line to an extra phono jack for use when dumping via the normal KIM-1 routine which does not know about the relays.

The following subroutine will permit control of the two cassettes:

0000	A9 02	WRITE	LDAIM	2	Use PBI for WRITE Operations
0002	10 02		BPL	TAPE	Unconditional Branch
0004	A9 01	READ	LDAIM	1	Use PBO for READ Operations
0006	4D 03 17	TAPE	EOR	1703	Toggle Bit in PB
0009	8D 03 17		STA	1703	Put Control Data in PB
000C	60		RTS		Return from Subroutine

A WRITE Operation would start with a JSR WRITE to get the WRITE cassette started. It would end with another JSR WRITE to stop the WRITE cassette. A READ Operation would start with a JSR READ to get the READ cassette started. It would end with another JSR READ to stop the READ cassette. The subroutine is completely relocatable.

PARTS LIST

	1N914 DIODE (2)	ELEC-TROL Reed Relay (3)
	.1z CAPACITOR (2)	7404 HEX INVERTER (1)
	10 ohm RESISTOR (2)	Miniature Phono Jack (2)

Price \$10.00



COMPUTER CONTROLLED RELAYS

Robert M. Tripp
8 Fourth Lane
S. Chelmsford, MA 01824

One of the easiest ways to expand the capabilities of a KIM-1 system is to provide a means of turning cassette tape recorders on and off under program control. This added capability permits a KIM-1, without a lot of additional memory, to perform editing, program assembly, mailing list maintenance, information retrieval, and other useful functions. One method of adding this computer control is by using relays as shown in the diagram below. To work reliably, a few components are required besides the relays.

The 7404 Hex Inverter is used to buffer the signals from the KIM's 6530 Port B I/O lines. There are many other IC chips which can also perform the buffering function. The 7404 was selected because it is so readily available.

The clipping diodes on the coils of the relays are there to prevent a reverse voltage spike, generated when the relay is turned off, from damaging the buffer chip. Note that some relays may come with this diode already built-in.

The resistor on the contact side of the relay serves to limit the current drawn from the device connected to the relay. This is required where the device does have a current source, such as the "remote" switch in most cassette tape recorders.

The capacitor on the contact side of the relay serves to dump excess current that may occur during the initial surge when the relay makes its closure. Without this capacitor, many relays will have their contacts "welded" shut after a few operations.

Note that the contact side of relays which do not carry significant current do not require either the resistor or capacitor.

The KIM-1 circuitry is such that during a READ operation a signal is also present on the AUDIO OUT lines. This will cause a problem on tape recorders whose electronics are not turned off in the "remote" state, since the record head is active and the signal being generated by the READ will be written on the tape. This can wipe out data on the tape. A solution is provided by a third relay which is connected in parallel with the WRITE REMOTE relay and which is used to control the AUDIO OUT line. The record head is now active only when the WRITE REMOTE is selected. The AUDIO OUT line should also be brought out to another phono jack for use when writing tape using the normal KIM-1 Dump routine which does not know about the relays.

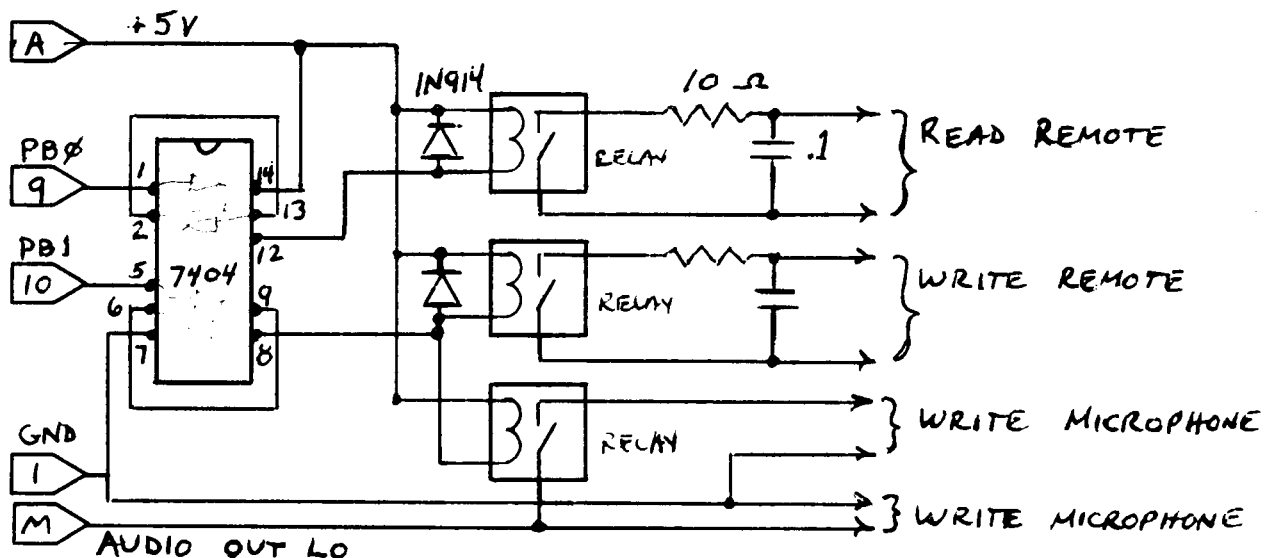

A SINGLE BOARD CONTROLLER
 WITH YOUR 2K PROM OR 4K ROM PROGRAM
A FULL DEVELOPMENT SYSTEM
 WITH OUR 5,120 BYTES OF ROM SOFTWARE
READY TO USE • READY TO SHIP
 IN REAL-TIME INDUSTRIAL PRODUCTS

SUPER JOLT features TINY BASIC,
 ASSEMBLER AND DEBUGGER ROMs on board!

ON ONE
 FULLY
 ASSEMBLED
 AND TESTED
 4 1/4" x 7" PC
 CARD YOU
 GET ALL:



- 8-bit 6502 processor • 1,024-byte static RAM • 32-bidirectional, programmable I/O lines • 1 MHz crystal controlled clock
- interval timer • 4 interrupts, including timer and non-maskable
- 3 serial interfaces: 20 mA current loop, RS 232 and TTL • 5,120 bytes resident ROM software including a single pass symbolic assembler, a TINY BASIC and a Debug Monitor.

AVAILABLE NOW. \$375 without Assembler and
 TINY BASIC ROMs. \$575 with ROMs!

MICROCOMPUTER ASSOCIATES, INC.
 2589 Scott Blvd., Santa Clara 95050
 (408) 247-8940

17
 COMMANDS

XIM

FOR
KIM
 (EXTENDED I/O MONITOR)

INCLUDES 4 USER DEFINED COMMANDS

- block move - block search - block compare - save
- and display CPU registers - process BRK points -
- enter - dump HEX data - enter-print ASCII text
- calculate branches - initialize data blocks -

AMPLIFIES THE POWER OF KIM's TTY MONITOR
 EASILY RELOCATED (resides at 2000_{hex})

45 PAGE MANUAL - LISTINGS

CASSETTE : \$12⁰⁰
 PAPER TAPE: \$10⁰⁰
 ppd USA

PYRAMID DATA SYSTEMS
 6 TERRACE AVE.
 NEW EGYPT, NJ 08533

KIM-1 with Power Supply \$245

In stock for immediate delivery.
 For educators, students, experimenters, hobbyists,
 system prototyping, instrumentation, and test
 systems.

SPECIAL — Includes Power Supply

KIM ACCESSORIES—

8K RAM — \$255

4K RAM — \$125

MTU 4 part harmony music board
 and amplifier — assembled and ready
 to hook to KIM (see Sept. 77 BYTE). **\$35**

PLEASE games and demo package on
 cassette. Includes digital clock, adding
 machine, decimal/hex and hex/decimal
 converter, games, others. **\$15**

MICROCHESS runs in 1K RAM
 — on cassette — \$13 **\$10**

ABC COMPUTERS

P.O. Box 104, Perkasio, PA. 18944

Power Supply for KIM \$34

KL Model 512

- Total capacity 4.5 amps
- + 5 volts regulated to 1.4 amp
- +12 volts regulated to 1.0 amp
- +8 volts to 4.5 amp
- +16 volts to 1.0 amp

Completely assembled, in case with connector
 cable, line cord, fused primary, short circuit and
 thermal protect.

Power Supply for KIMSI or general use \$51

KL Model 816

- +8 volts — 9 amp
- +16 volts — 1 amp
- 16 volts — 1 amp

Completely assembled, in case, and ready to use.

5 volt regulated and other supplies available.

DEALER AND QUANTITY PRICES AVAILABLE

KL POWER SUPPLIES

P.O. Box 86
 Montgomeryville, PA. 18936

6502 Bibliography

William Dial
438 Roslyn Avenue
Akron, OH 44320

1. MOS Technology, Inc., 950 Rittenhouse Rd., Norristown, PA 19401 "KIM-1 Microcomputer Module Users Manual (1975)"
2. MOS Technology, Inc., 950 Rittenhouse Rd., Norristown, PA 19401 "6502 Programming Manual"
3. MOS Technology, Inc., 950 Rittenhouse Rd., Norristown, PA 19401 "6502 Hardware Manual"
4. Fylstra, Daniel, "Son of Motorola (or the \$20 CPU chip)" Byte 1 No. 2, pp. 56-62 (November 1975)
Notes on the introduction of the MOS Technology MCS 6500 series microprocessors.
5. MOS Technology, Inc., 950 Rittenhouse Rd., Norristown, PA 19401 "MCS 6500 Microcomputer Family Cross Assembler Manual — Preliminary" (August 1975)
6. Rehnke, Eric C., Editor, "KIM-1/6502 Users Notes", P.O. Box 33077, North Royalton, OH 44133
Published about 6 times per year. The single most useful source of programs and miscellaneous information on the KIM-1.
7. MOS Technology, Inc., 950 Rittenhouse Rd., Norristown, PA 19401 "Users Manual — Memory Expansion Modules KIM-2 and KIM-3" (September 1976)
8. MOS Technology, Inc., 950 Rittenhouse Rd., Norristown, PA 19401 Flyer ca. March 1976 — "MCS 6530 Memory, I/O, Timer, Array"
A description of the 6530 ROM used on KIM-1.
9. MOS Technology, Inc., 950 Rittenhouse Rd., Norristown, PA 19401 "TIM Manual" (March 1976)
10. MOS Technology, Inc., 950 Rittenhouse Rd., Norristown, PA 19401 "KIM-1 Application Note No. 2"
Describes Interval Timer Operation. Helps to clarify the use of the timer. See also examples in the KIM monitor 6530-002 and -003.
11. Ohio Scientific Instruments, 11679 Hayden Ave., Hiram, OH 44234 "Model 300 Computer — Trainer Lab Manual"
A series of 20 programs for instruction on the 6502 microprocessor based Model 300 Trainer. Programs are easily adapted to KIM-1 operation.
12. Ohio Scientific Instruments, 11679 Hayden St., Hiram, OH 44234 "OSI Application Note No. 1"
Covers 6530 TIM Monitor.
13. Ohio Scientific Instruments, 11679 Hayden St., Hiram OH 44234 "Application Note No. 2"
OSI 480 Backplane and Expansion System.
14. Ohio Scientific Instruments, 11679 Hayden St., Hiram, OH 44234 "OSI Application Note No. 5"
Interfacing OSI Boards to other systems including KIM-1.
15. Ohio Scientific Instruments, 11679 Hayden St., Hiram, OH 44234 "OSI Model 430 Super I/O Board Instruction Manual"
16. Ohio Scientific Instruments, 11679 Hayden St., Hiram, OH 44234 "Model 420C, 4K Memory Expansion Board"
Instruction Manual — use together with OSI Application Note No. 2 on the 480 Backplane and Application Note No. 5 on interfacing OSI boards to other systems including KIM-1.
17. ON-LINE, 24695 Santa Cruz Hwy., Los Gatos, CA 95030
This classified ad newsletter often announces KIM-1 and 6502 software and hardware accessories. 18 issued \$3.75.
18. Helmers, Carl, "There's More to Blinking Lights Than Meets the Eye" Byte 1, No. 5, pp.52-54 (January 1976)
A program for creating patterns of flashing lights (LEDs).
19. Lloyd, Robert G., "There's More to Blinking Lights, etc." KIM-1/6502 Users Notes
A KIM-1 version of Carl Helmers earlier program in Byte.
20. Ziegler, John, "Breakpoint Routine for 6502" Dr. Dobbs Journal 1, No. 3, pp. 17-19 (1976)
Requires a terminal and a TIM Monitor. Upon entering, the program counter is printed, followed by the active flags, accumulator, register, Y register and stack pointer.

21. Anon., "What's New Kim-o-sabee?" Byte 1, No. 8, p. 14 (April 1976)
Brief notes on KIM-1.
22. Simpson, Richard S., "A Date with KIM" Byte 1, No. 9, pp. 8-12 (May 1976)
A description of the features of KIM-1.
23. Microcomputer Associates, 111 Main St., Los Altos, CA 94022 "Jolt Microcomputer" Radio-Electronics 47, No. 6, p.66 (June 1976)
Includes description of JOLT, based on 6502, and gives demonstration program using DEMON Monitor.
24. Travis, T.E., "KIM-1 Microcomputer Module" Microtrek, pp. 7-16 (August 1976)
Notes and programs for KIM-1 including Drunk test and several useful routines.
25. Anon., "MOS Technology — KIM MCS 6502" Interface Age 1, No. 9, pp. 12, 14 (August 1976)
An announcement of the KIM-1.
26. Rankin, Roy and Wozniak, Steve, "Floating Point Routines for the 6502" Dr. Dobbs Journal 1, No. 7, pp. 17-19 (August 1976)
Calculation from 10^{-38} to 10^{+38} with 7 significant digits.
27. Bradshaw, Jack, "Monitor for the 6502" Dr. Dobbs Journal 1, No. 7, pp. 20-21 (August 1976)
Monitor a la OSI.
28. Garetz, Mark, "Lunar Lander for the 6502" Dr. Dobbs Journal 1, No. 7, pp. 22-25 (August 1976)
A game requiring TIM Monitor and a terminal.
29. Gupta, Yogesh M., "True Confessions: How I Relate to KIM" Byte 1, No. 12, pp. 44-48 (August 1976)
A series of notes on KIM-1. Includes Clock Stretch and Random Access Memories, Bus Expansion and modification of drive capability using tristate drivers, Interrupt Prioritizing Logic and Halt Instruction.
30. Thompson, Geo. L., "KIM on, Now" Byte 1, No. 13, pp. 93-94 (September 1976)
Notes on using KIM-1.
31. Wozniak, Steve, "Mastermind: A Number Game for the 6502" DDJ 1, No. 8, pp. 26-27 (September 1976)
A number game adaptable to KIM-1 with terminal.
32. Baum, Allen and Wozniak, Stephen, "A 6502 Dissembler" Interface Age 1, No. 10, pp. 14-23 (September 1976)
33. Kjeldsen, Tony, "Next of KIM" (letter) Byte 1, No. 14, p. 136 (October 1976)
34. Pittman, Tom, "Tiny Basic for 6502" DDJ 1, No. 9, pp. 22-23 (October 1976)
Available from Itty Bitty Computers. TB650K (0200-OAFF) is for KIM and most homebrew 6502 systems with RAM in first 4K memory.
35. Anon., "Build a Simple A to D" Interface Age 1, No. 12, pp. 12-14 (November 1976)
Simple circuit, 6502 software, 16 locations. Use to interface a pot or a joystick.
36. Rankin, Roy and Wozniak, Stephen, "Floating Point Routines for 6502" Interface Age 1, No. 12, pp. 103-111 (November 1976) — See also DDJ 1, No. 7, pp. 17-19 (August 1976)
Contains good annotated listings. Loads 1DOO-1FEE.
37. Ohio Scientific Instruments, 11679 Hayden St., Hiram, OH 44234 Flyer: "OSIs New 8K Basic for 6502"
Written by Microsoft. Has automatic string space handling and runs up to 8 times faster than 8080 Basic. Cost \$50.
38. Cybersystems, Inc., 4306 Governors Drive West, Huntsville, AL 35805 Flyer: "The Microcyber 1000"
A complete microcomputer system based on a repackaged KIM-1. Provides power supply, two separate ports for I/O, TTY connector, Audio Cassette connector, room for expansion board, etc.
39. Microsoft Software Specialists, Inc., 2024 Washington, Commerce, TX 75428 Flyer: Assembler/Text Editor Program (4K)
Compatible with MOS Technology Assembler. Documentation and cassette \$19.50.
40. United Microsystems Corp., 2601 S. State St., Ann Arbor, MI 48104 Flyer: "UMCKIM/ALPHA"
A modular system based on memory modules of 4K and 8K, full keyboards, modular back-planes. Cost ca. \$700. Video monitor extra.

41. Riverside Electronic Design, Inc., 1700 Niagara St., Buffalo, NY 14207 Flyer: "KEM, KIM-1 Expansion Module and MVM-1024, Microprocessor Video Module"
Used for expansion of KIM-1 system with boards having S-1-- edge connectors ASCII keyboard interface. MVM-1024 is a video display board, scrolling, edit functions, 16 rows of characters, blinking cursor, etc.
42. 6502 Program Exchange, 2920 Moana, Reno, NV 89509 Flyer of April 1977 lists 7 programs for KIM-1 with 1 to 4K of memory and keyboard facilities.
43. DATA1-K Assembler Flyer November 10, 1976
A resident assembler for KIM-1. Model DATA1-K is compatible with MOS Technology Cross Assembler Language.
44. Pollock, James W., "1000 WPM Morse Code Typer" 73 Mag. No. 196, pp. 100-103 (January 1977)
Use of KIM-1 for sending code at 9-1000 WPM from a keyboard.
45. Robbins, Carl M., "The Microprocessor and Repeater Control" QST 61, No. 1, pp. 30-34 (January 1977)
KIM-1 control of repeater functions.
46. Inman, Don, "Data Handler Users Manual" Peoples Computer Co. 5, No. 4, pp. 10, 11, 13 (January-February 1977) Peoples Computer Co. 5, No. 5, pp. 16, 17, 18 (March-April 1977) Peoples Computer Co. 5, No. 6, pp. 52, 53, 55 (May-June 1977)
A how-to course in 6502 programming.
47. Miller, Lindsay, "Found, A Use for Your Computer" Kilobaud, Issue No. 2, p. 80 (February 1977)
A clock program for the KIM-1.
48. Gordon, H.T., "Stringout Mods" DDJ 2, No. 2, p. 8 (February 1977)
A 6502 program applicable to KIM-1 to relocate blocks of instructions in RAMs.
49. Fugitt, Lemuel A., "A 6502 Op Code Table" Byte 2, No. 3, p. 36 (March 1977)
See also Allen, Syd, "6502 Op Code Table" in KIM-1/6502 Users Notes, Issue 4, p. 9 (March 1977).
50. Kushnier, R., "A Partial KIM-1 Bibliography" KIM-1/6502 Users Notes No. 4, p. 7 (March 1977)
51. Cushman, Robert H., "Bare-bones Development Systems Make Good Learning Tools" EDN 22, No. 6 (March 20, 1977) See also 22, No. 8, pp. 104-111 (April 20, 1977) 22, No. 4, pp. 89-92 (February 20, 1977) 22, No. 10, pp. 84-90 (May 20, 1977) 22, No. 12, pp. 79-84 (June 20, 1977)
Use of KIM-1 in a music program is detailed in April 1977 issue.
52. Salter, Richard J. and Burham, Ralph W., "Navigation with Mini-0" Byte 2, No. 4, pp. 100-109 (April 1977); See also Byte 2, No. 2, p. 62 (February 1977) and Byte 2, No. 3, p. 70 (March 1977)
Several articles in a series on the Omega Navigation System and the Mini-0 Receiver driven by a KIM-1 processor. Developed at the Ohio University Avionics Engineering Center.
53. Haas, Bob, "KIM-1 Memory Expansion" Kilobaud, No. 4, pp. 74-76 (April 1977)
Adding the S.D. Sales 4K Low Power RAM board to KIM-1.
54. Sherman, Ralph, "A 650X Program Relocater" DDJ 2, No. 4, pp. 30-31 (April 1977)
55. Ockers, Stan, "TV Sketch Program" DDJ 2, No. 4, pp. 32-33 (April 1977)
A program for use with KIM-1 equipped with a Southwest Tech Prod Co. Graphics Board GT 6144.
56. Jennings, Peter R., "Microchess" DDJ 2, No. 4, p. 33 (April 1977)
Description of chess playing program. Cost \$10.
57. Wear, Tom, 380 Belaire, Punta Gorda, FL 33950, Private Communication April 20, 1977
Information on bringing up new memory boards with KIM-1, including OSI 420 and OSI 480 backplane. Includes a very nifty memory test routine for checking the operation of memory boards. See also KIM-1/6502 Users Notes No. 5, p. 4 (May 1977).
58. Loffbourrow, Tod Interface Age (April 1977)
All about a robot named Mike -- based on KIM-1.
59. Tripp, Robert M., "PLEASE" Flyer: The Computerist, May 1977
Fun and Games with KIM-1. A cassette in Supertape for fast loading into KIM-1. Has a number of interesting programs including clock, timer, billboard, travelling display, drunk test, Hi-Lo number game, etc. Available for \$10 from Robert M. Tripp, P.O. Box 3, S. Chelmsford, MA 01824.
60. Jennings, Peter, "Microchess" The Computerist Flyer, May 1977
Play Chess with KIM-1 with no additional peripherals or memory. Available from Robert M. Tripp for \$15.

61. The Computerist, P.O. Box 3, S. Chelmsford, MA 01824 Flyer May 2, 1977
Offers power supplies for KIM-1, also a relay kit to permit KIM to control two reed relays for two cassette recorders.
62. Computer Shop, 288 Norfolk St., Cambridge, MA 02139 Adv. in The Computerist, p. 18, May 1977
Offers a 4K RAM board for \$74.50 that can be used with KIM-1.
63. Riverside Electronics, 1700 Niagara St., Buffalo, NY 14207 Advertisement. See KIM-1/6502 Users Notes No. 5 (May 1977)
Offers 5 Application Notes for \$1 on the use of their MVM-1024 and KEM expansion boards. Ask for MVM-1, 2, 3, 4, 5 and KIM-1.
64. Aresco, 314 Second Ave., Hahhon Hts., NJ 08035 See KIM-1/6502 Users Notes, Issue No. 5, p. 1 (May 1977)
Lists several programs available for KIM, TIM, etc.
65. Simpson, Rick, "Come Fly with KIM" Byte 2, No. 6, pp. 76-80 (June 1977)
Load 12K of memory in two minutes with a "Fly Reader" for paper tape.
66. Lancaster, Don, "A TVT for your KIM" Kilobaud, No. 6, pp. 50-63 (June 1977)
TVT-6L is a low cost method of providing a TV monitor for KIM-1. Uses minimum new hardware but depends on a software program in KIM-1 memory for handling characters. Uses a low cost TV (Panasonic T-126A) for monitor.
67. Lancaster, Don, "Build the TVT-6" Popular Electronics 12, No. 1, pp. 47-52
A low cost direct video display based on KIM-1 software and a minimum of added hardware. Slightly different than the TVT-6L.
68. Pickles and Trout, P.O. Box 2270, Goleta, CA 93018 "TV Mod Kit"
Detailed instructions and kit of parts for conversion of a low cost (\$80 approx.) Hitachi SX Chassis (Model P-04, P-08, PA-8, etc.) for a TV Monitor.
69. Forethought Products, P.O. Box 386, Coburg, or "KIMSI" The Computerist, p. 8 (June 1977)
KIMSI is a motherboard/Interface that allows KIM-1 to be interfaced to an S-100 bus; 8 slots.
70. MOS Technology/Commodore "PET" The Computerist, p. 17 (June 1977)
An announcement on PET, a new 6502 system with video monitor, ASCII keyboard, 12 K ROM including 8 K Basic and 4 K RAM, audio cassette; price ca. \$4.95, available September 1977.
71. Grater, Robert, "Giving KIM Some Fancy Jewels" Byte 2, No.7, pp. 126-127 (July 1977)
Adding a remote LED display for the KIM-1.
72. Runyan, Grant, "The Great TV to CRT Monitor Conversion" Kilobaud, No. 7, pp. 30-31 (July 1977)
Although not specific to KIM-1, this article is useful in adapting a monitor to KIM. Uses inexpensive 12" Hitachi Model P-04, P-08, PA-4, PA-8. See also Sams Photofact Folder 1 Set 1601 or Folder 3 Set 1501.
73. Simpson, Richard, "KIM Forum" Kilobaud, No. 7, pp. 4, 19, 86 (July 1977)
KIM-5 will be a ROM expansion board with up to 8 MCS 6504 (2K x 8) mask programmed ROMs. One ROM is KIMath, a set of subroutines for doing floating point arithmetic. Cost \$50. Programming Manual for KIMath purchased separately is \$15. Also a resident assembler and text editor are available as a set of 3 ROMs.
74. Tripp, Robert M., "The 6502 World" The Computerist, p. 16 (July 1977)
MOS Technology may offer a 16K RAM board for KIM-1. New KIM repair facility is KIM Diagnostig Center 2967 W. Fairmont Ave. Phoenix, AZ 85017 Tele. 602-248-0769
4K Ram for KIM-1 assembled and tested for only \$129 available from Tripp.
75. Tripp, Robert M., "HELP Relay Package" The Computerist Flyer July 5, 1977
Components for relay control of 2 cassette recorders. Includes control program subroutine.
76. Tripp, Robert M., "4K RAM Board" The Computerist Flyer July 5, 1977
4K for KIM-1, socketed chips, 5.25" x 9.25" board, can separately address each 1K. Cost \$129 assembled.
77. Tripp, Robert M., "Digital to Analog Converter" The Computerist Flyer July 1977
Micro Technology Unlimited DAC board with audio output to drive 8/16 ohm speakers. Can play 4 part harmony with only KIM-1. Includes cassette tape program for tunes.
78. Tripp, Robert M., "Mod to Improve the PLEASE Clock" The Computerist July 5, 1977

79. Boyle, Peter, "The Gory Details of Cassette Storage" Kilobaud, No. 3, pp. 116-119 (March 1977)
Comments on audio cassette problems. States that KIM runs at 133 baud but is capable of 1200 baud.
80. Johnson Computer, P.O. Box 523, Medina, OH 44256 "Basic for KIM-1" μ P No. 4 (June 1977)
Resides in 2K at address 2000. Available in paper tape \$5.
81. Johnson Computer, P.O. Box 523, Medina, OH 44256 "Harness Eliminator" μ P No. 4 (June 1977)
Minimize wiring in connecting KIM 2 or 3 to KIM-1 with a rigid coupling.
82. Johnson Computer, P.O. Box 523, Medina, OH 44256 "KIM-1 Resident Assembler/Text Editor Model DATA1-K" μ P No. 4 (June 1977)
Use with MOS Tech Cross Assembler Manual.
83. Johnson Computer, P.O. Box 523, Medina, OH 44256 "KIMath - Floating Point Math Package" μ P No. 4 (June 1977)
Rom is \$50. Documentation alone \$15. Available from Johnson Computer.
84. Tripp, Robert M., "Is the KIM-1 for Every-1" Kilobaud, No. 8, pp. 56-57 (August 1977)
General description of KIM-1.
85. Fish, Larry, "Troubleshoot Your Software" Kilobaud, No. 8, pp. 112-113 (August 1977)
A trace program for 6502.
86. Severson, Gerald D., "Plaudits for MOS Technology" DDJ 1, No. 6, pp. 5 (June-July 1976)
Note on good service from MOS technology on the 6502.
87. Western Data Systems, 3650 Charles St., No. Z, Santa Clara, CA 95050 "Western Data's 6502-Based Data Handler" DDJ 1, No. 6, p. 43 (June-July 1976)
A \$170 kit with hex keyboard, LED binary readout, 1 K ram, capability of addressing 65K, uses 100 pin tustate bus and is compatible with a long list of Altair peripherals, 100 pin connector.
88. Espinosa, Chris, "A String Output Subroutine for the 6502" DDJ 1, No. 8, p. 33 (September 1976)
This routine saves pointers, loops, etc. in outputting the string.
89. Meier, Marcel, "6502 String Output, Revisited" DDJ 1, No. 10, p. 50 (November 1976)
Further mod of Espinosa's earlier routine.
90. Anon., "That didn't Take Long at All" Byte 1, No. 5, p. 74 (January 1976)
Note on 6502 product introduction and the JOLT computer kit.
91. Anon., "Control Logic for Microprocessor Enables Single Step" Electronic Design, p. 78 (October 11, 1976)
Uses 6502 system.
92. Anon., "6502 Disassembler" Interface Age, p. 14 (September 1976)
93. Butterfield, Jim, "KIM Goes to the Moon" Byte 2, No. 4, pp. 8-9, 132 (April 1977)
A lunar lander program; see also same program in KIM-1/6502 users notes.
94. Hybrid Technologies, P.O. Box 163, Burnham, PA 17009 "Ad for KIM-1 Peripherals" Byte 2, No. 8, p. 157 (August 1977)
2K/8K ROM based, EProm Programmer, 2K/4K/8K Ram boards, assembler board, TV Interface board, relay board, mother boards.
95. Simpson, Richard, "Circular Ad for 6502 Software" Aresco, 314 Second Avenue, Haddon Heights, NJ 08035, July 26, 1977
Describes FOCAL, a 4K language similar to BASIC, and a 2.5K resident assembler suitable for all 6502-based micro systems.
96. Commodore International, Ltd., 901 California Avenue, Palo Alto, CA 94304 Tele. (415) 326-4000 "The PET!" Peoples Computers 6, No. 1, p. 59 (July-August 1977)
An announcement of the PET computer based on 6502. Available early September 1977 for \$595.
97. Crow, Darrell - Microcomputer Associates, 2589 Scott Blvd., Santa Clara, CA 95050 Tele. (408) 247-8940 "6502 Assembler, Tinz Basic on ROM's" Peoples Computers 6, No. 1, p. 60 (July-August 1977)
RAP is a 1.75K Resident Assembler Program on two 2K ROM's together with 2.2K Tinz Basic, pin compatible with 2708-type PRoms - price \$200.
98. Inman, Don, "The Data Handler Users Manual Part 4" Peoples Computers 6, No. 1, pp. 42-46 (July-August 1977) (Cont. from Item 46)
Covers indexed addressing.

99. Anon., "User Group Being Formed for Commodore PET 2001 Computer" ON LINE 2, No. 10, p. 11 (August 3, 1977)
Membership is \$5 including User Notes. Contact Gene Beals, P.O. Box 371, Montgomeryville, PA 18936.
100. Anon., "6502 Assembler/Text-Editor for KIM-1 and TIM" ON LINE 2, No. 10, p. 10 (August 3, 1977)
Resides in 2K, requires Teletype or CRT and cassette recorder. \$29.95. M.S.S., Inc., 1911 Meadow Lane, Arlington, TE 76010
101. Anon., "MICRO-ADE" ON LINE 2, No. 10, p. 6 (August 3, 1977)
New Product Announcement by MICRO-WARE Ltd., 27 Firstbrooke Rd., Toronto, Canada, M4E2L2 Micro-Ade, a 4K package is a compact development tool for all 6502 users including KIM-1. User manual, hex dump, object program on paper tape or KIM cassette is \$25. Complete annotated source listing is available for another \$25.
102. Ohio Scientific Instruments, 11679 Hayden, Hiram, OH 44234
OSI Small Systems Journal (first regular July 1977) is a new publication, \$6 for six issues, devoted to 6502 and OSI users.
103. Deckant, Gary, "Understanding and Using the 6502 Assembler" OSI Small Systems Journal 1, No. 1, p. 8 (July 1977)
Explains use of assembler program.
104. Anon., "1K Corner" OSI Small Systems Journal 1, No. 1, p. 8 (July 1977)
The game of 23NIMB for OSI 65V systems. Requires terminal. Resides 0200-0332.
105. Cheiky, Mike and Meier, Marcel, "The Auto-Load Cassette System" OSI Small System Journal 1, No. 1, pp. 9-14, (July 1977)
For OSI 65V system.
106. Anon., "The 6502 Disassembler — From Object to Source End" OSI Small System Journal 1, No. 1, pp. 14-15 (July 1977)
A disassembler is a program which attempts to convert machine code back into assembler source. Obviously it cannot reconstruct comments or labels. Points out other pitfalls in using disassemblers.
107. Pyramid Data Systems, 6 Terrace Ave., New Egypt, NJ 08533 Ref :KIM-1/650X, Users Notes No. 6, p. 1 (July 1977)
XIM is an extended I/O monitor package for Kim, residing in about 1K memory. Adds 17 commands to terminal equipped Kim. Has 45-page user manual. Cost \$12.00 for manual and KIM cassette.
108. ORB, P.O. Box 311, Argonne, Ill., 60439, "The First Book of KIM" Ref: KIM-1/650X, Users Notes No. 6, p.1 (July 1977)
Ockers, Rehnke and Butterfield have collaborated in a 180-page new book to guide beginners and others in the use and enjoyment of KIM-1. Cost \$9.50 including postage.
109. Aresco, 314 Second Ave., Haddon Hts., NJ 08035, "Comprehensive 650X Assembler/Text Editor" Ref: KIM-1/650X Users Notes No. 6, p. 4 (July 1977)
Designed for use with KIM-1 but can be used with other 650X systems such as TIM, Apple, Baby, OSI, etc. — Occupies 6K, available on KIM cassette or KIM-TIM paper tape. Cost \$60.00.
110. Bates, Dan, Rt 7, Box 310, Claremore, Okla, 74017, "Small Microcomputer Board using 6505. Ref: KIM-1/650X, Users Notes No. 6, p. 9 (July 1977)
Bates has developed a board around the 28 pin 6505 and sells the 6" x 4" PC board for \$15.00 including schematic and assembly instructions. Can handle ASCII to Baudot, micro-controlled repeater/autopitch, etc.
111. Laabs, John, "Build a \$20 EPROM Programmer" Kilobaud No. 9, pp. 70-77, (Sept 1977)
KIM-1 is used to run software and some external hardware to program the 5204 4K EPROM.
112. Ohio Scientific Instruments, Hiram, Ohio, 44234, "A Computer that Thinks in BASIC" Kilobaud No. 9, p. 10, (Sept 1977)
Announcement of OSI's Model 500 CPU board built on 6502. Complete with 8K Basic in ROM for \$298.
113. Clarke, Sheila, "A PET for Every Home" Kilobaud No. 9, pp. 40-42, (Sept 1977)
A look at the Commodore PET 2001 based on the 6502. About \$600 includes Video terminal keyboard, 12K, (8K Basic in ROM and 4K operating system).

114. American Institute for Professional Education, Carnegie Bldg., Hillcrest Road, Madison, NJ, 07940, "Microprocessing Fundamentals" Circular Advertisement — approx. Aug. 15, 1977.
Dr. Joseph B. Ross, Purdue Univ. and Dr. Garnett Hill, Oklahoma State Univ. will present a course in Fall of 1977 at several locations. Course is based on KIM-1 hardware together with instruction in Digital Devices, Programing Fundamentals, Advanced Programing, Peripherals, I/O addressing, applications, etc. Cost about \$600 including a KIM-1 to keep after the course.
115. Gregson, Wilfred J. II, "RTTY with the KIM" 73 Magazine 9, No. 204, p. 110-112 (Sept 1977)
A clever program for using KIM-1 and the 6-digit LED display as a readout for a RTTY signal. Simply feed the audio from a receiver into the tape input of KIM-1 and read the message as it flows across the display (about 45.5 baud, 60 wpm). Can also handle other ratio to 100 baud). Can also use KIM-1 as a display only, operating from an already available terminal unit.
116. Synertek 3050 Coronado Drive, Santa Clara, CA 95051 Misc. Data Sheets received by mail.
Describes second source of 6502 and associated microprocessor chips by Synertek. SY6502 is updated to include ROR function. Other chips include SY6530, SY6522 (PIA), SY6532, SY6520, etc.
117. Rockwell International, 3310 Miraloma Ave., P.O. Box 3669, Anaheim, CA 92803 Data Sheets D39 thru D44 received by mail.
Describes Rockville R6502 microprocessor and other second source Microprocessor accessory chips including R650X, R651X, R6520 (PIA) R6530 (ROM, RAM, I/O, Timer) R6532, etc. R6502 also available in 2 MHz option. R6502 has the updated ROR function.
118. Bumgarner, John O., "A-KIM-1 Sidereal/Solar Clock" Interface Age 2, No. 9, p. 36-37 (Aug 1977)
119. Atkins, R. Travis, "A New Dress for KIM" Byte 2, No. 9, p. 26-27 (Sept 1977)
Describes mounting the KIM-1 in a briefcase together with power supply, prototype boards, etc.
120. Chamberlin, Hal, "A Sampling of Techniques for Computer Performance of Music" Byte 2, No. 9, p. 62-83 (Sept 1977)
General Discussion of Music Generation plus detailed information on application to KIM-1 and a description of the hardware and software for a D/A music board and software package being marketed by Micro Technology Unlimited, 29 Mead St., Manchester, NJ 03104. PC board alone is \$6.00, assembled and tested D/A board \$35.00, software package on KIM cassette is \$13.00 additional.
121. Beals, Gene, P.O. Box 371, Montgomeryville, PA 18936, "User Group for the Commodore PET 2001 Computer" Ref: On Line 2, No. 11, p. 2 (Aug 24, 1977)
Yearly membership \$5.00 brings Users Notes publication.
122. Cater, J., 11620 Whisper Trail, San Antonio TX 78230, "Run OSI 6502 8K Basic on your TIM or JOLT" On Line 2, No. 11, p. 3 (Aug 24, 1977)
Cost \$4.00 for annotated source and object code of patches for TIM or JOLT."
123. Firth, Mike, 104 N. St. Mary, Dallas, Texas 75214, "Large Type Summary of Command Coder for 6502 plus addresses." On Line 2, No. 11, p. 8 (Aug 24, 1977) Cost: \$0.13 stamp plus SASE.
124. House, Gil, P.O. Box 158, Clarksburg, Md., 20734, "6502 Legible Tape Labeler." On Line 2, No. 11, p. 9 (Aug 24, 1977)
A program for TIM (JOLT DEMON), Hex tape and documentation \$4.00
125. Kushe, Willi, "KIM-1 Breakpoint Routines Plain and Fancy" DDJ 2, No. 6, pp. 25-26 (June-July 1977)
A modified routine using KIM-1 Monitor allows size to be cut to only 124 Bytes.
126. F and D Associates, Box 183, New Plymouth, OH 45654 On Line 2, No. 9, p. 9 (July 13, 1977)
New product Announcement: Video Display Board compatible with 6502. Two pages 16 lines x 64 characters, scrolling, screen erase. Bare Board \$29 incl. software and documentation.
127. Staff Article "PET Computer" Peoples Computers 6, No. 2, p. 22-27 (Sept-Oct. 1977)
Chuck Peddle, father of the PET is interviewed. Interesting comments on the marketing of this 6502 based microcomputer and accessories.
128. Inman, Don, "The Data Handler Users Manual: Part 5" Peoples Computers 6, No. 2, pp. 50-55 (Sept-Oct. 1977)
Covers Session VII — Writing Programs

COMPUTER SHOP

288 NORFOLK ST. CAMBRIDGE, MASS. 02139
corner of Hampshire & Norfolk St. 617-661-2670

MEMORY 4 K MEMORY KITS THAT CAN EASILY BE ADAPTED TO YOUR KIM

The V.F8 4K memory kits have dual 22 pin .156 pinouts but with different pin assignments than your KIM. Instructions for jumpering between connectors are included. This board has been used as modified by many KIM owners.....KIT \$74.50

LOW POWER RAM add 10.00
FULL SET SOCKETS add 10.00

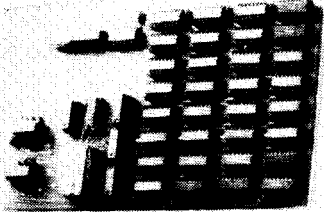

V.F8 MOTHERBOARDS allow you to plug in up to 4 4K memory boards. It has on board buffering.....KIT \$65.00

We have an 8K Memory board with 2K EPROM space under development but are not taking orders yet. Watch for announcement.

A CONNECTOR BOARD is available that adapts the V.F8 4K Memory Board to the KIM-1 with a minimum of connections. Assm...\$20.00

CS 100 A Packaged S100 Bus 6502 System



The CS100 6502 SYSTEM is a S100 BUS system based upon our new S100 package with the CGRS S100 Boards. The complete system consists of:

- *Folding removable keyboard cabinet
- *Power Supply *Motherboard *Six Connectors
- *Keyboard *Fan * 6502 Front Panel Board
- *6502 CPU Board with 1K RAM *Terminal Input
- *Monitor*16K Static RAM *S100 Video Terminal
- *Hitachi Modified TV

COMPLETE KIT.....\$1529.00

ASSEMBLED AND TESTED.....\$1989.00

You can now have all of the advantages of the S100 Bus with CGRS designed S100 6502 Boards that are now available in Kit form:

CS100 CGRS 6502 CPU RAM ROM Bd.\$ 169.95

CS100 CGRS TIM 6820 I/ O Board....\$ 129.95

CS100 CGRS Switch/ Hex Front Panel\$ 129.95

KIM I The most popular assembled microcomputer\$249.00

ORDER COMPUTER SHOP 288 NORFOLK ST.
CAMBRIDGE, MASS. 02139

BAC,VISA,MC NO.

SIGNATURE.....

NAME.....

ADDRESS.....

CITY.....STATE.....ZIP.....

V.F8 4K Ram Kit.....\$ 74.50()

Low Power 2102 Option.....\$ 10.00()

Socket Option.....\$ 30.00()

V.F8 Motherboard.....\$ 65.00()

Connector Board.....\$ 20.00()

CS100 TIM Kit.....\$ 129.95()

CS100 6502 CPU Kit.....\$ 169.95()

CS100 Front Panel Kit.....\$ 129.95()

CS100 6502 17K System Kit...\$ 1529.00()

CS100 6502 17K System Assm.\$ 1989.00()

KIM-1.....\$ 249.00()

Total of Order.....\$.....

Mass. Res. Sales Tax.....\$.....

Shpg. 1% (\$2.00 minimum)....\$.....

Total Remittance or Charge...\$.....

LDA	AD	LDAIM	A9	LDAZ	A5	LDAIX	A1	LDAIY	B1	LDAZX	B5	LDAX	BD	LDAY	B9	N	Z
STA	8D			STAZ	85	STAIK	81	STAIY	91	STAZX	95	STAX	9D	STAY	99		
ADC	6D	ADCIM	69	ADCZ	65	ADCIX	61	ADCIY	71	ADCZX	75	ADCX	7D	ADCY	79	N	Z
SBC	ED	SBCIM	E9	SBCZ	E5	SBCIX	E1	SBCIY	F1	SBCZX	F5	SBCX	FD	SBCY	F9	N	Z
AND	2D	ANDIM	29	ANDZ	25	ANDIX	21	ANDIY	31	ANDZX	35	ANDX	3D	ANDY	39	N	Z
EOR	4D	EORIM	49	EORZ	45	EORIX	41	EORIY	51	EORZX	55	EORX	5D	EORY	59	N	Z
ORA	0D	ORAIM	09	ORAZ	05	ORAIX	01	ORAIY	11	ORAZX	15	ORAX	1D	ORAY	19	N	Z
CMP	CD	CMPIM	C9	CMPZ	C5	CMPIX	C1	CMPIY	D1	CMPZX	D5	CMPX	DD	CMPY	D9	N	Z
ASL	0E	ASLA	0A	ASLZ	06					ASLZX	16	ASLX	1E			N	Z
LSR	4E	LSRA	4A	LSRZ	46					LSRZX	56	LSRX	5E			N	Z
ROL	2E	ROLA	2A	ROLZ	26					ROLZX	36	ROLX	3E			N	Z
ROR	6E	RORA	6A	RORZ	66					RORZX	76	RORX	7E			N	Z
DEC	CE			DECZ	C6					DECZX	D6	DECX	DE			N	Z
INC	EE			INCZ	E6					INCZX	F6	INCX	FE			N	Z
BIT	2C			BITZ	24											7	Z

6

LDX	AE	LDXIM	A2	LDXZ	A6					LDXZY	B6			LDXY	BE	N	Z
STX	8E			STXZ	86					STXZY	96						
CPX	EC	CPXIM	E0	CPXZ	E4											N	Z
DEX	CA	INX	E8													N	Z

LDY	AC	LDYIM	A0	LDYZ	A4					LDYZX	B4	LDYX	BC			N	Z
STY	8C			STYZ	84					STYZX	94						
CPY	EC	CPYIM	C0	CPYZ	C4											N	Z
DEY	88	INY	C8													N	Z

BPL	10	BMI	30	BVC	50	BVS	70	BCC	90	BCS	B0	BNE	D0	BEQ	F0						
CLC	18	SEC	38	CLI	58	SEI	78			CLV	B8	CLD	D8	SED	F8						
JMP	4C	JMPI	6C	JSR	20	RTS	60	RTI	40	BRK	00	NOP	EA								
<u>TAX</u>	<u>AA</u>	<u>TXA</u>	<u>8A</u>	<u>TAY</u>	<u>A8</u>	<u>TYA</u>	<u>98</u>	<u>TSX</u>	<u>BA</u>	<u>TXS</u>	<u>9A</u>					<u>N</u>	<u>Z</u>				
PHA	48	PLA	68	PHP	08	PLP	28	(Flags Restored)												<u>N</u>	<u>Z</u>

I	=	Indirect		A	=	Accumulator
IM	=	Immediate		Z	=	Zero page
X	=	absolute indexed by X		Y	=	absolute indexed by Y
IX	=	Indexed indirect by X		IY	=	Indirect indexed by Y
ZX	=	Zero page indexed by X		ZY	=	Zero page indexed by Y

No extension for Relative, Implied or Absolute addressing modes.

LEAST SIGNIFICANT DIGIT

	0	1	2	4	5	6	8	9	A	C	D	E
0	BRK	ORAIX			ORAZ	ASLZ	PHP	ORAIM	ASLA		ORA	ASL
1	BPL	ORAIY			ORAZX	ASLZX	CLC	ORAY			ORAX	ASLX
2	JSR	ANDIX		BITZ	ANDZ	ROLZ	PLP	ANDIM	ROLA	BIT	AND	ROL
3	BMI	ANDIY			ANDZX	ROLZX	SEC	ANDY			ANDX	ROLX
4	RTI	EORIX			EORZ	LSRZ	PHA	EORIM	LSRA	JMP	EOR	LSR
5	BVC	EORIY			EORZX	LSRZX	CLI	EORY			EORX	LSRX
6	RTS	ADCIX			ADCZ	RORZ	PLA	ADCIM	RORA	JMPI	ADC	ROR
7	BVS	ADCIY			ADCZX	RORZX	SEI	ADCY			ADCX	RORX
8		STAIK										
9	BCC	STAIY		STYZ	STAZ	STXZ	DEY		TXA	STY	STA	STX
A	LDYIM	LDAIX	LDXIM	STYZX	STAZX	STXZY	TYA	STAY	TXS		STAX	
B	BCS	LDAIY		LDYZX	LDAZX	LDXZY	CLV	LDAY	TSX	LDYX	LDAX	LDXY
C	CPYIM	CMPIX		CPYZ	CMPZ	DECZ	INY	CMPIM	DEX	CPY	CMP	DEC
D	BNE	CMPIY			CMPZX	DECZX	CLD	CMPY			CMPX	DECX
E	CPXIM	SBCIX		CPXZ	SBCZ	INCZ	INX	SBCIM	NOP	CPX	SBC	INC
F	BEQ	SBCIY			SBCZX	INCZX	SED	SBCY			SBCX	INCX

ASCII CONVERSION TABLE

HEX	0	1	2	3	4	5	6	7
BITS	000	001	010	011	100	101	110	111
0 0 0 0 0	NUL	DLE	SPACE	0	@	P	`	p
1 0 0 0 1	SOH	DC1	!	1	A	Q	a	q
2 0 0 1 0	STX	DC2	"	2	B	R	b	r
3 0 0 1 1	ETX	DC3	#	3	C	S	c	s
4 0 1 0 0	EOT	DC4	\$	4	D	T	d	t
5 0 1 0 1	ENQ	NAK	%	5	E	U	e	u
6 0 1 1 0	ACK	SYN	&	6	F	V	f	v
7 0 1 1 1	BEL.	ETB	'	7	G	W	g	w
8 1 0 0 0	BS	CAN	(8	H	X	h	x
9 1 0 0 1	HT	EM)	9	I	Y	i	y
A 1 0 1 0	LF	SUB	*	:	J	Z	j	z
B 1 0 1 1	VT	ESC	+	;	K	[k	{
C 1 1 0 0	FF	FS	,	<	L	\	l	
D 1 1 0 1	CR	GS	-	=	M]	m	}
E 1 1 1 0	SO	RS	.	>	N	^	n	~
F 1 1 1 1	SI	US	/	?	O	_	o	DEL

HEXIDECIMAL CONVERSION TABLE

HEX	0	1	2	3	4	5	6	7	8	9	A	B	C	D	E	F	00	000
0	0	1	2	3	4	5	6	7	8	9	10	11	12	13	14	15	0	0
1	16	17	18	19	20	21	22	23	24	25	26	27	28	29	30	31	256	4096
2	32	33	34	35	36	37	38	39	40	41	42	43	44	45	46	47	512	8196
3	48	49	50	51	52	53	54	55	56	57	58	59	60	61	62	63	768	12288
4	64	65	66	67	68	69	70	71	72	73	74	75	76	77	78	79	1024	16384
5	80	81	82	83	84	85	86	87	88	89	90	91	92	93	94	95	1280	20480
6	96	97	98	99	100	101	102	103	104	105	106	107	108	109	110	111	1536	24576
7	112	113	114	115	116	117	118	119	120	121	122	123	124	125	126	127	1792	28672
8	128	129	130	131	132	133	134	135	136	137	138	139	140	141	142	143	2048	32768
9	144	145	146	147	148	149	150	151	152	153	154	155	156	157	158	159	2304	36864
A	160	161	162	163	164	165	166	167	168	169	170	171	172	173	174	175	2560	40960
B	176	177	178	179	180	181	182	183	184	185	186	187	188	189	190	191	2816	45056
C	192	193	194	195	196	197	198	199	200	201	202	203	204	205	206	207	3072	49152
D	208	209	210	211	212	213	214	215	216	217	218	219	220	221	222	223	3328	53248
E	224	225	226	227	228	229	230	231	232	233	234	235	236	237	238	239	3584	57344
F	240	241	242	243	244	245	246	247	248	249	250	251	252	253	254	255	3840	61440